

yellobrik[®]

LYNX[™]Technik

Product
Catalog
2026 Q2

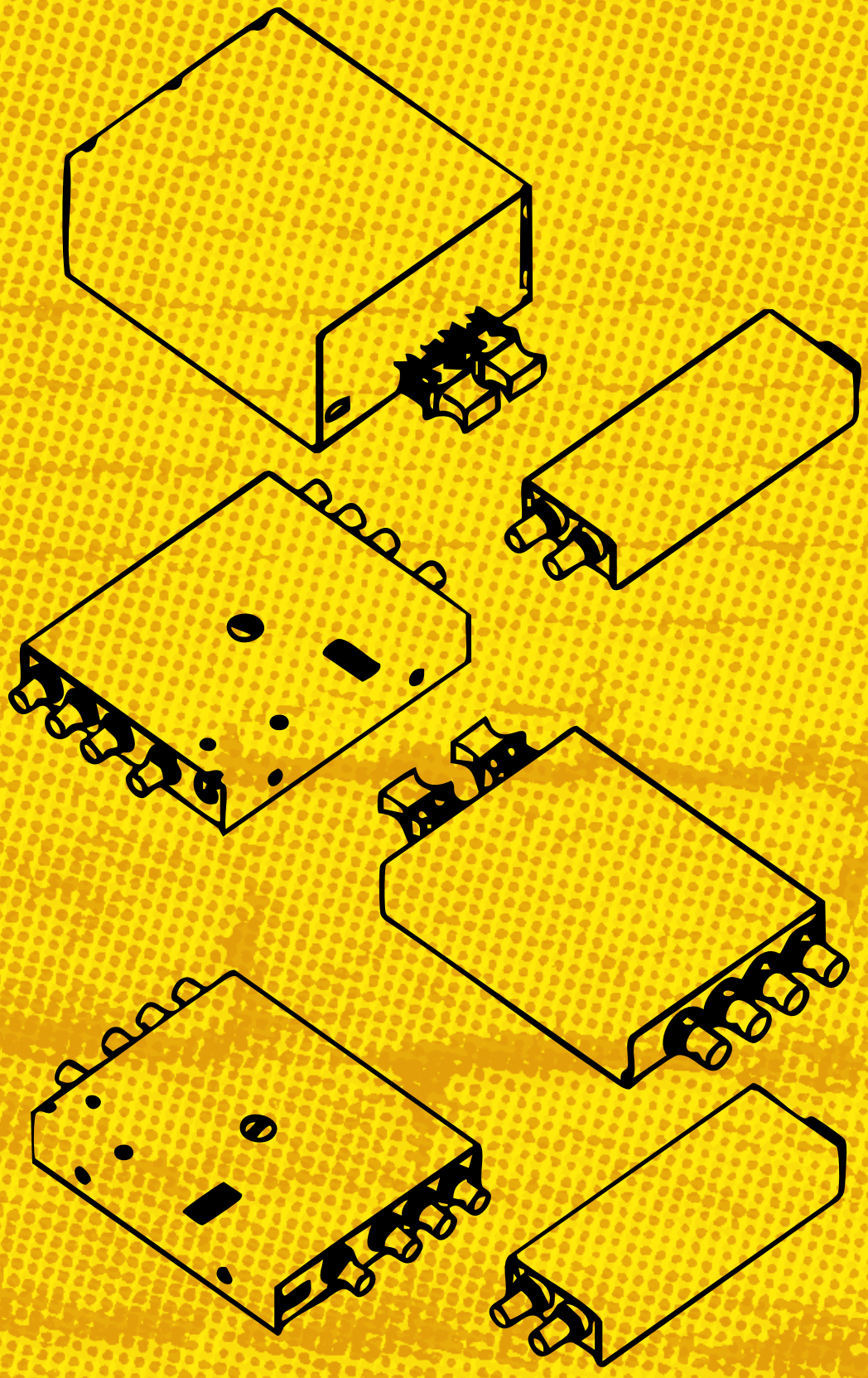

Contents

CDE 1922	1	ORR 1402.....	9
3G-SDI / ST 2110 Bidirectional Converter		2-Channel Fiber to 12G-SDI Receiver	
PEC 1464.....	1	OTX 1410	9
H.265 Streamer and Recorder		12G-SDI to Fiber Transmitter	
IDC 1411	1	ORX 1400.....	9
12G-SDI AI Voice Cleaner, Filter and Amplifier		Fiber to 12G-SDI Receiver	
CHD 1412	2	OTT 1814.....	10
HDMI to 12G-SDI Converter and Frame Synchronizer		4-Channel 3G-SDI to Fiber Transmitter	
CHD 1402.....	2	ORR 1804.....	10
HDMI to 12G-SDI Converter		4-Channel Fiber to 3G-SDI Receiver	
CHD 1812-1.....	2	OTT 1812-1	10
HDMI to 3G-SDI Converter and Frame Synchronizer		2-Channel 3G-SDI to Fiber Transmitter	
CHD 1802-1	2	ORR 1802-2	10
HDMI to 3G-SDI Converter		2-Channel Fiber to 3G-SDI Receiver	
CDH 1411	3	OTX 1812	10
12G-SDI to HDMI Converter		3G-SDI to Fiber Transmitter	
SPG 1708	3	ORX 1802-2	10
Sync Pulse Generator		Fiber to 3G-SDI Receiver	
OTX 1712-2.....	3	OTR 1814	11
Analog Sync/Video to Fiber Transmitter		4-Channel 3G-SDI to Fiber Transceiver	
CDH 1813.....	3	OBD 1810-2	11
3G-SDI to HDMI Converter		3G-SDI Bidirectional Transceiver	
ORX 1702-1.....	3	OTR 1810-1	11
Fiber to Analog Sync/Video Receiver		3G-SDI to Fiber Transceiver	
PMV 1841.....	4	OTR 1210.....	11
3G-SDI to HDMI Multiviewer		MADI Coax to Fiber Transceiver	
CQS 1462	4	OBD 1814.....	11
12G-SDI to 3G-SDI Bidirectional Converter		4-Channel 3G-SDI to Fiber Transceiver	
PVD 1400.....	5	OBD 1210.....	11
12G-SDI Frame Synchronizer		MADI Coax to Fiber Transceiver	
PDM 1484 D	5	OCM 1841/OCM 1842/OCM 1843/OCM 1844	12
12G-SDI AES/Analog Audio Embedder / De-Embedder		4 Channel CWDM Mux/Demux	
PDM 1484 B.....	5	OCM 1800.....	12
12G-SDI AES Audio Embedder / De-Embedder		19 Channel CWDM Mux/Demux 1270nm-1610nm	
PVD 1800.....	5	OCM 1891/OCM 1892	12
3G-SDI Frame Sync with UPXD		9 Channel CWDM Mux/Demux	
PDM 1383	5	OSP 1812/OSP 1812M/OSP 1814	12
3G-SDI Analog Audio Embedder / De-Embedder		Passive Optical Splitters	
DVD 1417	6	OSW 1022.....	12
12G-SDI 1x7 Distribution Amplifier		2x2 Optical Switch	
DVD 1423	6	OTR 1A41 / OTR 1A42.....	13
2-Channel 12G-SDI 1x3 Distribution Amplifier		8K Fiber Transmission System	
DVD 1817	6	RCT 1012.....	13
3G-SDI 1x7 Distribution Amplifier		yellobrik Rack Controller	
DVA 1714	6	OTR 1441 / OTR 1442.....	13
Wide Band 1x4 Analog Distribution Amplifier		4k Fiber Transmission System	
DVD 1823	6	SRV 1000	13
2-Channel 3G-SDI 1x3 Distribution Amplifier		yellobrik Server Module	
OBD 1510 D	7	RFR 1200.....	14
Serial and GPI Fiber Transceiver		19" Rack frame for yellobriks	
OBD 1514 E.....	7	RFR 1018	14
1GbE to Fiber Transceiver		19"/0.5RU mounting tray	
OET 1514.....	7	RFR 1001	14
1GbE to Fiber Transceiver (switch)		Single yellobrik mounting bracket	
OET 1910.....	7	Appendix I: Power Supply Holder.....	15
10GbE to Fiber Transceiver		Appendix II: Power Adapter Options	15
ODT 1510	7	Appendix III: Power Supplies.....	15
Serial and GPI Fiber Transceiver		Appendix IV: Fiber Adapter Options.....	16
OBD 1910.....	7	Appendix V: SFP Options.....	17
10GbE to Fiber Transceiver			
OTR 1414.....	8		
4-Channel 12G-SDI to Fiber Transceiver			
OTR 1410.....	8		
12G-SDI to Fiber Transceiver			
OBD 1414.....	8		
4-Channel 12G-SDI to Fiber Transceiver			
OBD 1410.....	8		
12G-SDI Bidirectional Transceiver			
OTT 1414.....	9		
4-Channel 12G-SDI to Fiber Transmitter			
ORR 1404.....	9		
4-Channel Fiber to 12G-SDI Receiver			
OTT 1412.....	9		
2-Channel 12G-SDI to Fiber Transmitter			

3G-SDI / ST 2110 Bidirectional Converter



- 2x 3G-SDI inputs, 2x 3G-SDI outputs
- 2x 10GbE Media LAN Fiber In-/Output
- 2x 1GbE RJ-45 Management LAN
- Full redundancy for IP links and Config
- NMOS Discovery, Connection and Audio Mapping
- Uncompressed Active Video (ST 2110-20)
- Seamless Protection Switching ST 2022-7

The CDE 1922 is a high performance 3G-SDI to/from IP ST 2110 bridge capable of handling up to four HD video streams simultaneously. The converter has 2x ST2110 encoders and 2x ST2110 decoders working simultaneously. Each encoder/decoder has a maximum of 8 audio channel. The CDE 1922 can be equipped with a pair of 10GbE Multi-mode, Single-mode or RJ45 SFPs. It can be managed via the control ports or the Media LAN connections.



Models: CDE 1922, CDE 1922 MM, CDE 1922 SM, CDE 1922 RJ45

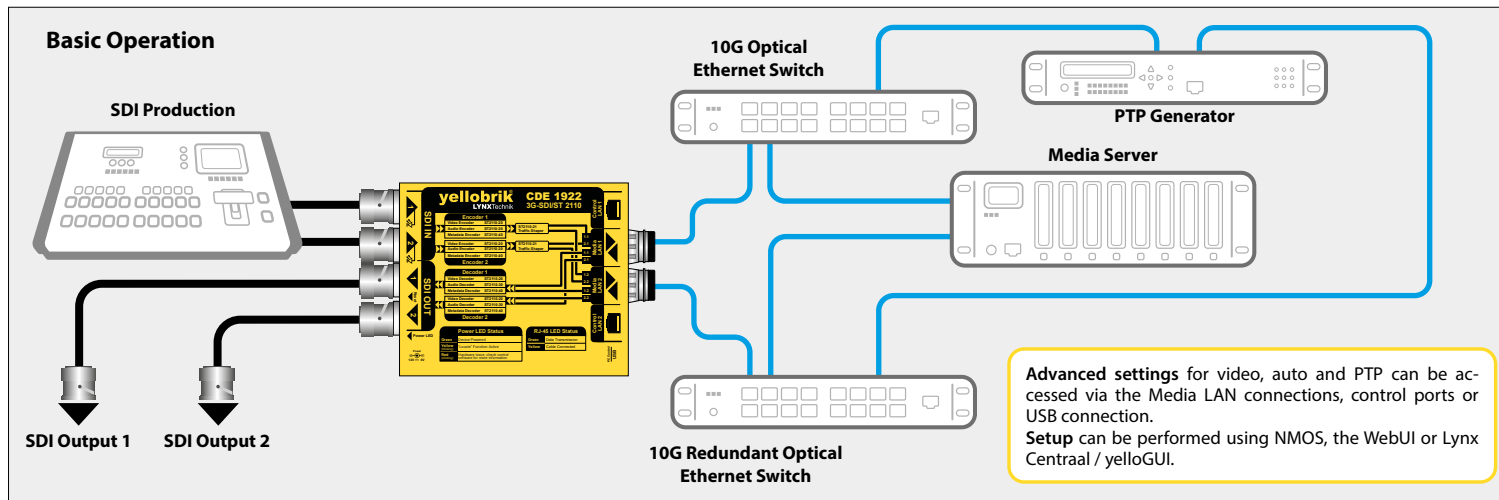

PEC 1464

H.265 Streamer and Recorder

- HDMI and 12G-SDI UHD video inputs
- Analog Audio Input
- H.264 and H.265 encoding
- Support for RTMPs, RTSP, TS, HLS, SRT
- Record to USB 3.0
- Realtime Logo Insertion and text overlays
- Image and Test Pattern Transmission fallback

The PEC 1464 can take a 12G-SDI or HDMI source then stream and record it simultaneously in h264/h265. Chose between the line audio input or one of the embedded SDI audio pair and use it for eSports, live event streaming, webcasts, conferencing, AV system monitoring, house of worship proceedings and many more.

Model: PEC 1461

IDC 1411

12G-SDI AI Voice Cleaner, Filter and Amplifier



- Supports 12G/3G/1.5G-SDI Video Standards
- Audionamix AI Dialogue Cleaner
- AES Input and Output
- Automatic Video / Audio Delay
- Speech & Background Gain, Compressor and more.

The IDC 1411 can be used to provide an enhanced speech channel for the hearing impaired, for pre-clearing speech ahead of automated subtitle and translation generators, or within security services to isolate speech in surveillance situations. It takes in 12G-SDI via BNC or fiber input, and AES based audio via a separate BNC input. SDI Output can be routed to fiber or BNC.

Model: IDC 1411

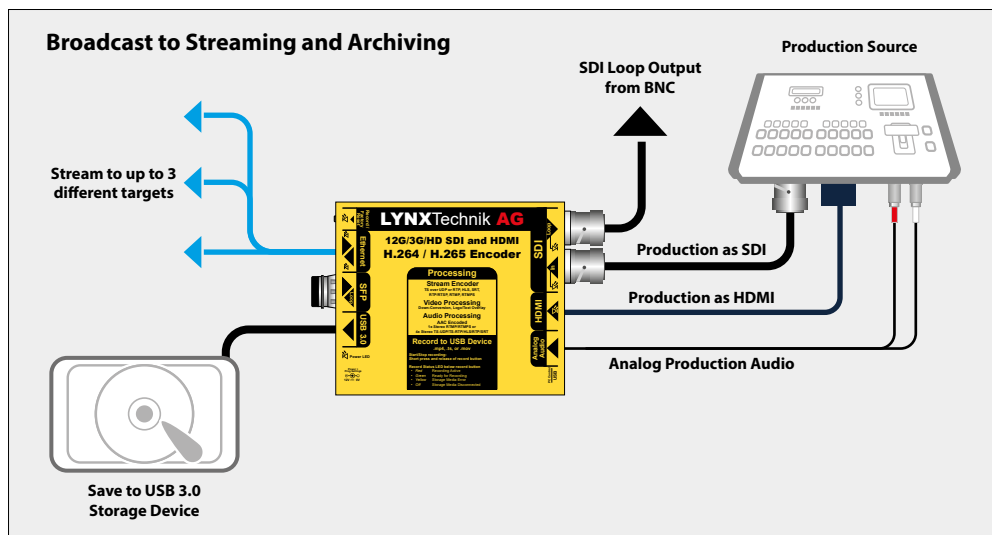

CHD 1412

HDMI to 12G-SDI Converter and Frame Synchronizer



- Supports 12G/6G/3G/1.5G/SD-SDI Signals
- Up to 4K DCI, 4:4:4, 12-bit
- Integrated Frame Synchronizer
- Multi-Format Reference Input & Cross Lock
- 2x SDI Outputs With Optional SDI Fiber Output
- Support PCM, Dolby E, D, DD+ and Atmos JOC
- Balanced Analog Audio, Unbalanced Line Level Audio and AES Inputs

The CHD 1412 is a versatile and compact HDMI to 12G-SDI converter with an integrated frame synchronizer. It is an ideal solution for any application which requires a fully synchronized SDI input from an external asynchronous HDMI source. It can handle video formats up to UHD and 4K DCI with 4:2:2 and 4:4:4 chroma sub-sampling at 8-bit, 10-bit or 12-bit depth.

A pair of stereo analog inputs can be embedded into any AES channel. Audio inputs can be either professional balanced audio with selectable full scale level, or unbalanced consumer line level audio.

Model: CHD 1412

60Hz HDMI to 59.94 12G-SDI Conversion

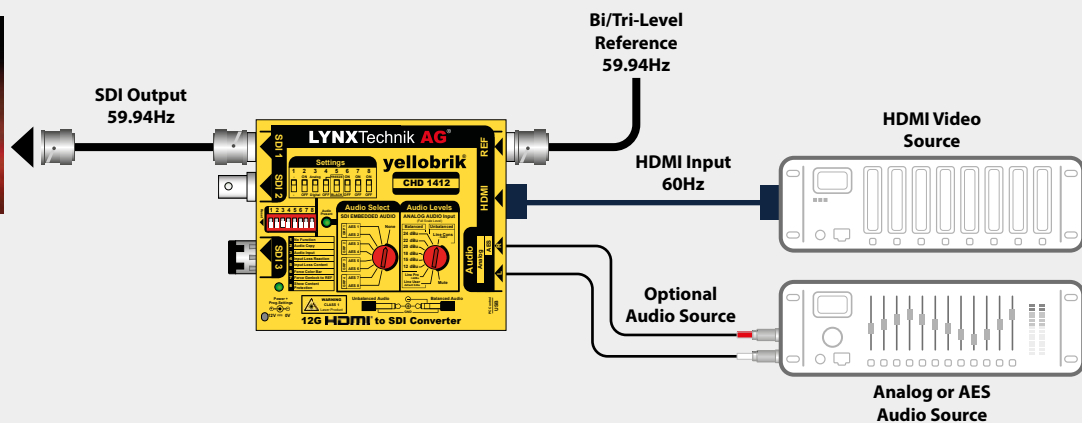

CHD 1402

HDMI to 12G-SDI Converter



- Supports 12G/6G/3G/1.5G/SD-SDI Signals
- Up to 4K DCI, 4:4:4, 12-bit
- 2x BNC and 1x optional Fiber SFP outputs
- PCM, Dolby E, D, DD+ and Atmos JOC Audio

The CHD 1402 is a compact HDMI to 12G-SDI converter, ideal for generating broadcast-quality 12G-SDI from an HDMI source. It embeds HDMI PCM audio into the SDI output and supports UHD and 4K DCI formats with 4:2:2 or 4:4:4 chroma at 8-, 10-, or 12-bit depth. A 12G-SDI fiber output with optional SFP modules is also provided.

Model: CHD 1402

CHD 1812-1

HDMI to 3G-SDI Converter and Frame Synchronizer



- Support 3G / 1.5G / SD-SDI and single link 3D
- HD and 2k DCI, 4:2:2 & 4:4:4, 8/10/12-bit
- Integrated Frame Synchronizer
- Multi-Format Reference Input & Cross Lock
- 2x SDI outputs with optional SDI fiber output
- HDMI embedded audio passed transparently
- 2x external analog audio inputs
- Selectable AES channel for audio embedding

The CHD 1812 is an HDMI to 3G-SDI converter with integrated frame synchronizer. It is an ideal solution for any application which requires a fully synchronized SDI input from an external asynchronous HDMI source. A pair of stereo analog inputs can be embedded into any AES channel, while audio from the HDMI stream is automatically passed through to the SDI output. The 3G-SDI fiber output is compatible with a wide range of plug-in SFP modules.

Model: CHD 1812-1

CHD 1802-1

HDMI to 3G-SDI Converter



- Support 3G / 1.5G-SDI and single link 3D
- 2x BNC SDI and 1x optional fiber outputs
- HDMI embedded audio passed transparently
- HDMI presence LED

The CHD 1802-1 is a compact HDMI to 3G-SDI converter. It is an ideal solution for any application which requires a broadcast quality 3G-SDI signal derived from an external HDMI source. Audio from the HDMI stream is embedded into the corresponding SDI channels. Optional SFP fiber output available.

Model: CHD 1802-1

CDH 1411

12G-SDI to HDMI Converter



- Support 12G/6G/3G/1.5G/SD-SDI Standards
- Up to 4k YCbCr/RGB 4:4:4 12-bit
- Support HDMI EOTF for HDR and WCG
- Analog and AES Audio Outputs
- Embedded Audio on HDMI
- TC, Metadata and Closed Caption burn-in
- 16 Channel on-screen audio level meter
- H/V delay & H flip with Safe Area markers

The CDH 1411 is a compact 12G-SDI to HDMI converter with a comprehensive set of on-screen burn-in features. It is designed for monitoring and displaying uncompressed video signals in broadcast, post-production, and professional AV environments. Optional fiber SFP connectivity adds optical transmission and/or reception capabilities. AES audio can be de-embedded from the 12G-SDI feed. Up to 8 audio channels can be embedded into the HDMI signal.

Model: CDH 1411



12G-SDI Monitoring with Overlay Options

Video Input via
Fiber or BNC

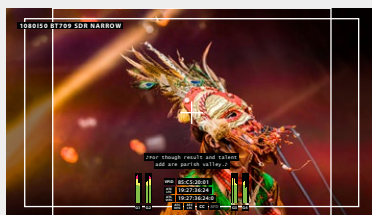
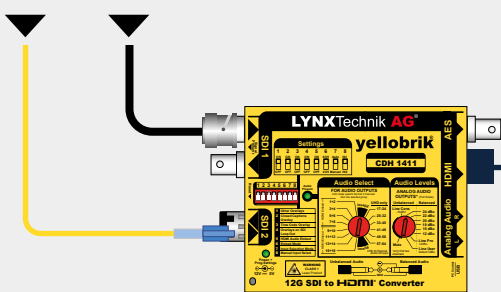

HDMI Output
with Overlays

SPG 1708

Sync Pulse Generator

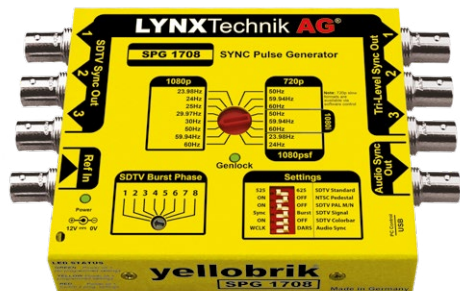

- Simultaneous Tri-Level and Bi-Level sync mode
- Genlock with cross lock to any sync standard
- Burst phase adjustment for NTSC and PAL sync
- Audio Sync output 48kHz Word Clock or DARS
- Support delay in line and pixels

The SPG 1708 is a compact sync pulse generator with genlock providing Bi-Level/Tri-Level video sync and WCLK/DARS audio sync.

The sync generator has an accuracy of 2ppm, is robust and temperature stabilized. The module locks to any SD, HD, and 3G-SDI reference input, with full cross-lock functionality and timing lock, even across unmatched standards. A delay in line and pixel can be applied.

Model: SPG 1708



OTX 1712-2

Analog Sync/Video to Fiber Transmitter



- Supports Black Burst, Bi-Level and Tri-Level
- Supports NTSC and PAL composite video
- Passive loop output
- Up to 10km* (6.2 miles) in single-mode
- Up to 300m* (984 feet) in multi-mode

The OTX 1712-2 is an analog sync/video to fiber transmitter.

When paired with the ORX 1702-1 fiber receiver it becomes an effective optical transmission system for sync signals. It is ideal for reference sync distribution between distant places. Its in house built technology maintain a very high degree of sync and burst phase stability during the conversion and fiber transmission.

Models: OTX 1712-2 LC, OTX 1712-2 ST, OTX 1712-2 SC, OTX 1712-2 MM



CDH 1813

3G-SDI to HDMI Converter



- Support 3G / 1.5G / SD-SDI and Single Link 3D
- Up to 2k YCbCr/RGB 4:4:4
- Support HDMI EOTF for HDR and WCG
- Analog and AES Audio Outputs
- Embedded Audio on HDMI
- Timecode and Metadata burn-in
- 16 Channel on-screen audio level meter
- H/V delay & H flip with Safe Area markers

The CDH 1813 is a versatile 3G-SDI to HDMI converter designed to meet a wide range of monitoring and display requirements in broadcast, post-production, and professional AV environments.

A comprehensive range of on-screen burn-in features enhances the CDH 1813's monitoring functionality: Timecode Burn-in, 16-channel Audio Metering, Safe Area Markers, Metadata Display etc. The optional SFP connectivity provides optical transmission and/or reception.

Model: CDH 1813



ORX 1702-1

Fiber to Analog Sync/Video Receiver



- Supports Black Burst, Bi-Level and Tri-Level
- Supports NTSC and PAL composite video
- Multimode version available
- Input range 1260nm to 1620nm single-mode
- CWDM compatible

The ORX 1702-1 is a fiber to analog sync/video receiver. When paired with the OTX 1712-2 fiber transmitter it becomes an effective optical transmission system for sync signals. It is ideal for reference sync distribution between distant places. Its in house built technology maintain a high degree of sync and burst phase stability during the fiber reception and analog conversion.

Models: ORX 1702-1 LC, ORX 1702-1 SC, ORX 1702-1 ST, ORX 1702-1 MM



PMV 1841

3G-SDI to HDMI Multiviewer



- Support 3G / 1.5G / SD-SDI formats
- 4x SDI inputs and 1x HDMI output
- Full Screen, Quad Split and UHD modes
- Integrated local control and on screen menus
- On screen monitoring for each input: Waveform, Vectorscope, Auto Level, IMD, Safe Area, TC etc.
- Integrated Test Signal Generator

The PMV 1841 is a compact quad split multiviewer ideal for applications needing basic quad split multiview capability into an HDMI monitor. Four SDI inputs are supported with a single HDMI output.

Model: PMV 1841

Drop-In Multiview



HDMI Output

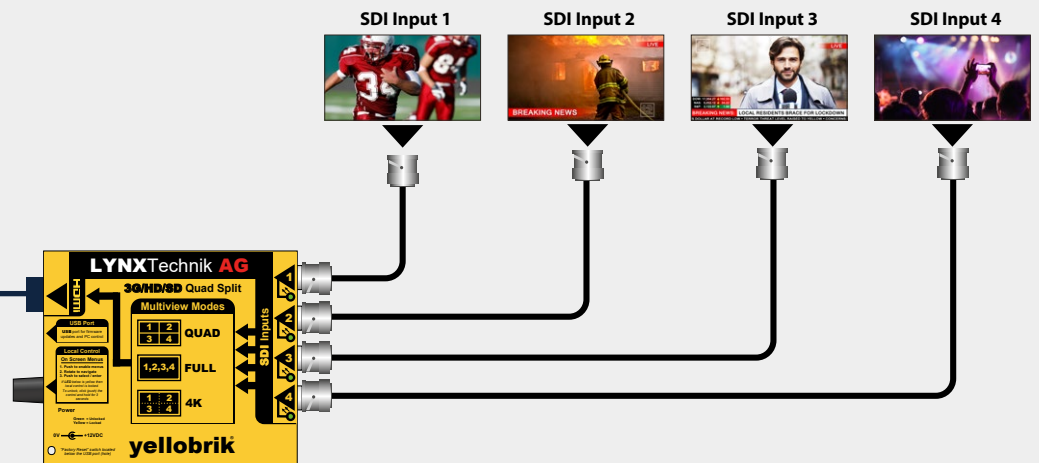

CQS 1462

12G-SDI to 3G-SDI Bidirectional Converter



- Support 12G/6G/3G/1.5G-SDI Video Formats
- 4x BNC and 1x Fiber Inputs
- 5x BNC and 1x Fiber Outputs
- 2SI/SQD Single to Quad and Quad to Single Link
- Automatic Link Loss Reply Options for 2SI/SQD
- 1 to 5+1 Distribution Amplifier mode

The CQS 1462 is a compact solution designed to bridge Quad Link 3G-SDI to Single Link 12G-SDI in 2SI and SQD. Operational mode can be selected from the local rotary switch or via control software. Link identification through on-screen overlays. Support for both CWDM and non-CWDM SFPs.

Model: CQS 1462

Quad Link to Single Link Conversion



12G-SDI to 4K Quad Conversion



1x6 Distribution Mode



1x5 Fiber to BNC Distribution



PVD 1400

12G-SDI Frame Synchronizer



- Supports 12G/6G/3G/1.5G/SD-SDI formats
- Converts 3G-SDI Level A to/from B Dual Link
- Robust “œfflywheel” synchronization
- “œCross lock” compatible reference input
- Integrated fall-back Test Pattern Generator
- Up to 30 frames delay (Frame/Line/Pixels)
- Optional Fiber SFP I/O

The PVD 1400 is a broadcast quality compact 12G-SDI frame synchronizer for professional applications in the Broadcast and Post Production industry. It can buffer up to 30 frames and generate Test patterns. All embedded audio is extracted and delayed automatically to match the video processing delay.

Model: PVD 1400

PVD 1800

3G-SDI Frame Sync with UPXD



- Supports 3G / 1.5G / SD-SDI (level A+B) formats
- Up/Down/Cross Converter
- Fast scale mode (<10 lines delay)
- Converter automated by AFD, WSS or VI mode
- Auto changeover or GPI switch between inputs
- 16 Audio Channels
- Up to 30 frames delay (Frame/Line/Pixels)

The PVD 1800 is a broadcast quality 3G-SDI frame synchronizer with high quality Up/Down/Cross conversion for professional applications in the Broadcast and Post Production industry. It can buffer up to 30 frames, generate Test patterns and switch inputs via GPI trigger. All embedded audio is extracted and delayed to match the video processing delay. It embeds a powerful Region of Interest (ROI) scaler.

Model: PVD 1800

Synchronize an asynchronous HDMI input to a broadcast reference.

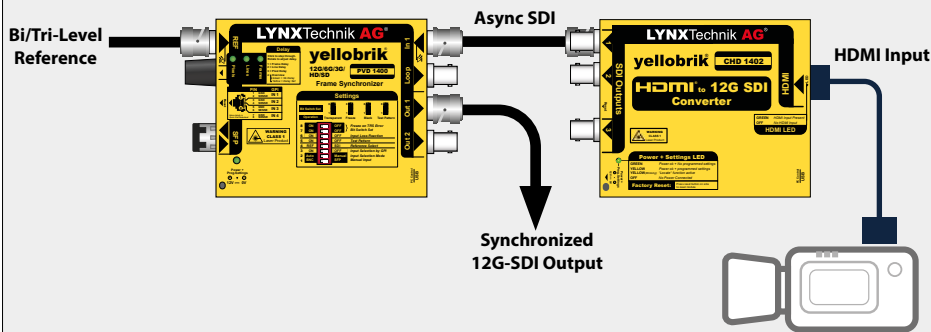

PDM 1484 D

12G-SDI AES/Analog Audio Embedder / De-Embedder



- Supports 12G/6G/3G/1.5G/SD-SDI Signals
- Up to 4K YCbCr/RGB 4:4:4
- Simultaneous audio de/embedding
- Bidirectional Audio Transport Mode
- 4x AES/Analog I/O with selectable audio groups
- Integrated 1 kHz Test Tone Generator
- Automatic PCM / Encoded Audio detection

The PDM 1484 D is a 12G-SDI Analog/AES audio Embedder and De-Embedder. Simultaneous de-embedding and embedding allows the module to output audio from the selected group before overwriting it with a new audio source for flexible real-time audio management.

Audio groups are selected using the two rotary switches. The “auto black” mode allows the module to work with no video source.

Model: PDM 1484 D

PDM 1484 B

12G-SDI AES Audio Embedder / De-Embedder



- Supports 12G/6G/3G/1.5G/SD-SDI Signals
- Up to 4K YCbCr/RGB 4:4:4
- Simultaneous audio de/embedding
- Bidirectional Audio Transport Mode
- 4x AES I/O with selectable audio groups
- Integrated 1 kHz Test Tone Generator
- Automatic PCM / Encoded Audio detection

The PDM 1484 B is a 12G-SDI AES audio Embedder and De-Embedder. Simultaneous de-embedding and embedding allows the module to output audio from the selected group before overwriting it with a new audio source for flexible real-time audio management.

Audio groups are selected using the two rotary switches. The “auto black” mode allows the module to work with no video source.

Model: PDM 1484 B

PDM 1383

3G-SDI Analog Audio Embedder / De-Embedder



- Support 3G / 1.5G / SD-SDI video formats
- Simultaneous audio de/embedding
- Bidirectional audio transport mode
- 4x Analog audio I/O with selectable groups
- Optional Fiber I/O
- Integrated 1 kHz Test Tone Generator
- Auto Black on missing input

The PDM 1383 is a 3G-SDI analog audio Embedder and de-Embedder. Analog audio inputs and outputs are provided via a D-Sub 25-pin connector. Simultaneous de-embedding and embedding allows the module to output audio from the selected group before overwriting it with a new audio source for flexible real-time audio management.

The “auto black” mode allows the module to work with no video input.

Model: PDM 1383

DVD 1417

12G-SDI 1x7 Distribution Amplifier



- Support 12G/6G/3G/1.5G/SD-SDI Video Formats
- Suitable for SDI video up to 4k DCI / UHD
- 1 input and 7 outputs
- Reclocking on all outputs
- Auto-detect input format

The DVD 1417 is a compact 1x7 12G-SDI distribution amplifier. The SDI input format is auto-detected and all outputs are reclocked.

The input LED lights when a valid input is detected. Like all yellobrik modules, it is compatible with the RFR 1200 rack frame, which provides power redundancy.

Model: DVD 1417

DVD 1817

3G-SDI 1x7 Distribution Amplifier



- Support 3G / 1.5G-SDI Video Formats
- Level A and Level B (all formats) and DVB-ASI
- 1x7 Distribution Mode
- Reclocking on all outputs
- Auto-detect input format

The DVD 1817 is a 1x7 3G-SDI reclocking distribution amplifier suitable for any level A or Level B SDI video signal including DVB-ASI.

The input presence LED lights up when a valid signal is detected. Like all yellobrik modules, it is compatible with the RFR 1200 rack frame, which provides power redundancy.

Model: DVD 1817

DVA 1714

Wide Band 1x4 Analog Distribution Amplifier



- 1x4 Distribution Mode
- Wide Band 30MHz
- Composite and Analog Video signals
- Bi-Level and Tri-Level Sync signals
- Adjustable Gain and EQ
- Input Clamp

The DVA 1714 is a compact 1x4 wide band analog distribution amplifier suitable for analog SDTV and HDTV video signals. It includes an input clamp with user adjustable gain and cable equalization.

It can be used with analog Bi-Level, Black Burst and Tri-Level sync pulses.

Model: DVA 1714

DVD 1423

2-Channel 12G-SDI 1x3 Distribution Amplifier



- Support 12G/6G/3G/1.5G-SDI Video Formats
- 2x3 Distribution Mode
- Reclocking on all outputs
- Auto-detect input format

The DVD 1423 is a 2-Channel 12G-SDI reclocking distribution amplifier. Each channel is 100% independent and can process different SDI formats. The SDI input format is auto-detected and all outputs are reclocked. The input LEDs light up when a valid input is detected.

Model: DVD 1423

DVD 1823

2-Channel 3G-SDI 1x3 Distribution Amplifier



- Support 3G / 1.5G-SDI Video Formats
- 2x3 Distribution Mode
- Reclocking on all outputs
- Auto-detect input format

The DVD 1823 is a 2-Channel 3G-SDI reclocking distribution amplifier. Each channel is 100% independent and can process different SDI formats. The SDI input format is auto-detected and all outputs are reclocked. The input LEDs light up when a valid input is detected.

Model: DVD 1823

Synchronize an asynchronous HDMI input to a broadcast reference.

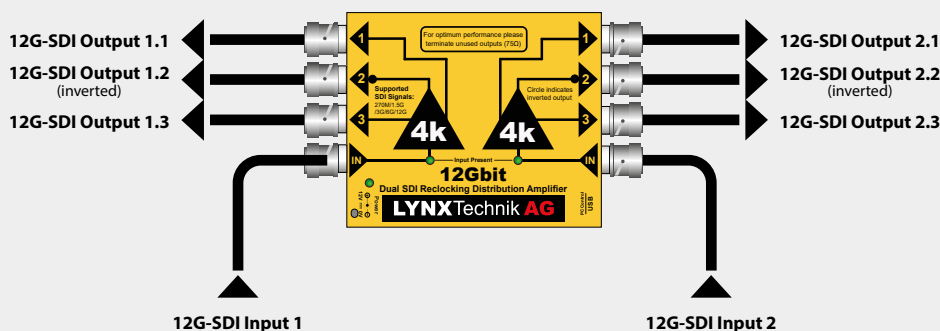

OBD 1510 D

Serial and GPI Fiber Transceiver

- Bidirectional converter over Single Fiber Link
- Extend serial and GPI connections up to 10km
- Supports Serial RS232, RS422 and RS485
- Protocol agnostic
- Switchable RX/TX crossover, Auto or Manual
- Plug and Play - No PC software drivers needed
- Simplex LC Fiber connection



The OBD 1514 E extends GPI and serial over a Bidirectional multiplexed single fiber link instead of two dedicated fibers for Tx and Rx. The kit includes two modules, Type A and Type B, with their power supplies, working together in a WDM closed-loop environment. The integrated dip switch provides control over the mode of operation with selections for the serial standard, serial termination, RX/TX crossover and RS422/485 data direction (automatic or manual).

Model: OBD 1510 D

Basic Application

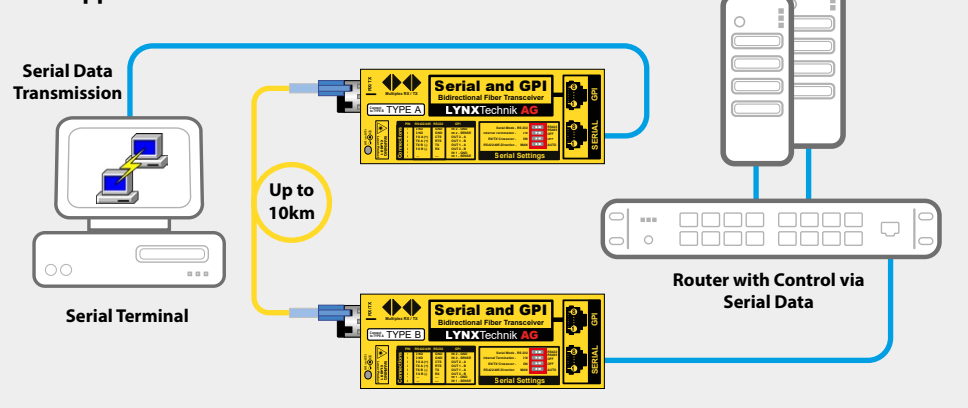

ODT 1510

Serial and GPI Fiber Transceiver



- Supports Serial RS232, RS422 and RS485
- 2x GPI connections
- Switchable RX/TX crossover, Auto or Manual
- Switchable end of line termination
- Single-mode or Multi-mode fiber
- LC/PC duplex fiber connections

The ODT 1510 is used to extend GPI and serial over a duplex fiber link. One RJ45 connection can be configured for serial standards, and one for two electrical GPI inputs and outputs.

The ODT 1510 is protocol agnostic. It supports mixing and matching of standards at data rates ranging from 300 to 460K Baud (auto sensing and auto adjusting). The transmitting module can take in RS232 and the receiving module can be set to output RS422.

Models: ODT 1510, ODT 1510 MM, ODT 1510 CW

OBD 1514 E

1GbE to Fiber Transceiver



- Supports standard ethernet inputs up to 1GbE
- 3 port ethernet switch (1 fiber, 2 electrical)
- Auto (10/100/1000) port speed detection
- Auto or manual electrical crossover selection
- Up to 10km(6.2 miles)* over single-mode fiber
- Simplex Bidirectional LC connection

The OBD 1514 E extends a 1GbE network up to 10km* over a Bidirectional multiplexed single fiber link instead of two dedicated fibers for Tx and Rx. The kit includes two modules, Type A and Type B, with their power supplies, working together in a WDM closed-loop environment.

The complete system functions as a 4 ports Ethernet switch, providing two standard RJ45 Ethernet ports at each end bridged with fiber.

Model: OBD 1514 E

OET 1514

1GbE to Fiber Transceiver (switch)



- Supports standard ethernet inputs up to 1GbE
- 3 port ethernet switch (1 fiber, 2 electrical)
- Auto (10/100/1000) port speed detection
- Auto or manual electrical crossover selection
- Up to 10km(6.2 miles)* over single-mode fiber
- Duplex LC connection

The OET 1514 is a compact 3 ports Ethernet switch, designed to extend the reach of Ethernet signals over long distances using a fixed 1 Gbit/s optical speed. When paired with another OET 1514 it becomes an effective Ethernet extender for distances up to 10km providing a stable, error free optical connection between locations. Each port can use auto crossover detection or be forced manually via dip switch.

Models: OET 1514, OET 1514 MM, OET 1514 CW

OET 1910

10GbE to Fiber Transceiver



- Supports 1GbE and 10GbE standards
- Compatible with Dante Audio and ST 2110
- Fiber to Copper and Copper to Fiber conversion
- Single-mode and Multi-mode versions available
- Up to 20km (12.4 miles) over Single-mode fiber
- Duplex LC fiber connection

The OET 1910 is a compact Ethernet to Fiber converter, designed to extend the reach of 1GbE and 10GbE signals over long distances. The module is a straight forward pass-through and does not provide bitrate conversion from 1GbE to 10GbE.

Models: OET 1910, OET 1910 MM, OET 1910 CW

OBD 1910

10GbE to Fiber Transceiver



- Supports 1GbE and 10GbE standards
- Compatible with Dante Audio and ST 2110
- Bidirectional Fiber to Copper conversion
- Single-mode and Multi-mode versions available
- Extend 10Gbit/s Ethernet up to 30km* (18.6 miles) on single-mode
- Simplex bidirectional LC fiber connection

The OBD 1910 is a plug and play solution to extend a 1GbE or 10GbE network up to 30km* over a Bidirectional multiplexed single fiber link instead of two dedicated fibers for Tx and Rx. The kit includes two modules, Type A and Type B, with their power supplies, working together in a WDM closed-loop environment.

Models: OBD 1910 E, OBD 1910 MM

OTR 1414

4-Channel 12G-SDI to Fiber Transceiver



- 12G-SDI Fiber receiver and transmitter
- Supports 12G/6G/3G/1.5G/SD-SDI video standards
- Auto reclocking
- 2x Duplex LC/PC connections
- Up to 10km* (6.2 miles) @ 12G-SDI single-mode

The OTR 1410 transceiver has two independent transmitters and receivers channels, which provide an effective solution for any 12G-SDI signals up to 4096x2160 60Hz. Operation of device is automatic. Video formats are automatically detected and relocked. It is compatible with the RFR 1200 rack frame, which provides power redundancy.

Models: OTR 1414, OTR 1414 CW

Example Connection Diagram

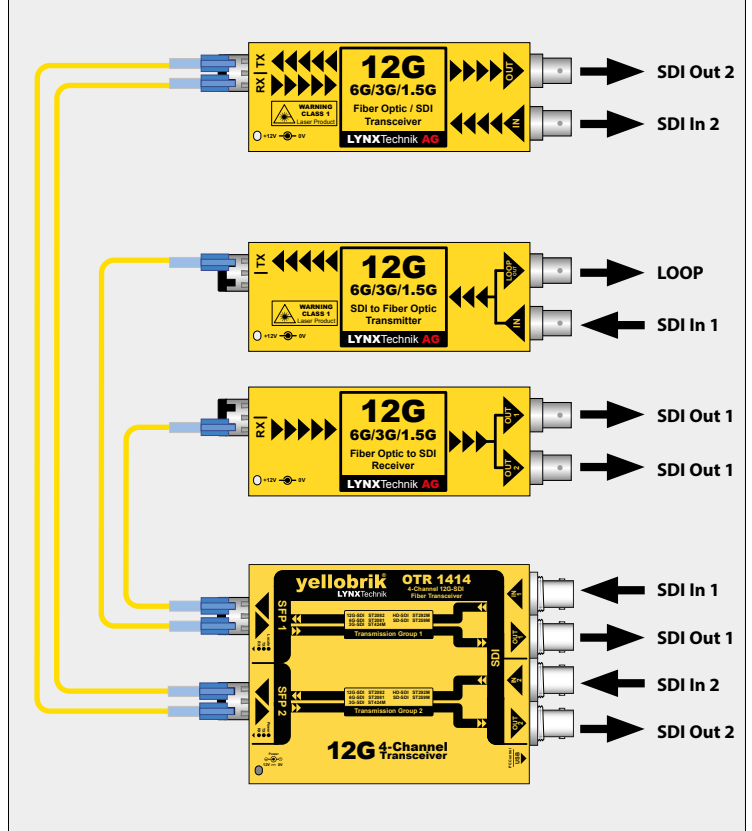

OTR 1410

12G-SDI to Fiber Transceiver



- 12G-SDI Fiber receiver and transmitter
- Supports 12G/6G/3G/1.5G/SD-SDI video standards
- Auto reclocking
- Duplex LC/PC connection
- Up to 10km* (6.2 miles) @ 12G-SDI single-mode

The OTR 1410 transceiver has an independent transmitter and receiver channel, which provide an effective solution for any 12G-SDI signal up to 4096x2160 60Hz. Operation of the receiver and transmitter is automatic. Video formats are automatically detected and relocked. It is compatible with the RFR 1200 rack frame, which provides power redundancy.

Models: OTR 1410, OTR 1410 CW

OBD 1414

4-Channel 12G-SDI to Fiber Transceiver



- 4-Channel 12G-SDI Fiber Transceiver
- Supports 12G/6G/3G/1.5G/SD-SDI video standards
- Auto reclocking
- Bidirectional converter over Single Fiber Link
- Up to 10km (6.2 miles) @ 12Gbit/s
- 2x Simplex LC/PC single-mode fiber connection

The OBD 1414 is a 4-Channel Bidirectional Fiber to 12G-SDI transmitter and receiver which uses two single fiber links supplied in a compact self contained package. It conveniently fit within 2RU height. The kit includes two modules with their power supplies, Type A and Type B, working together in a WDM closed loop environment. Each module has two 12G-SDI input and output. It uses a pair of Simplex (single fiber) links between the two devices. Each channel is fully independent and can support different standards and formats of SDI video. The modules auto-detect and re-clock any video signal.

Model: OBD 1414

OBD 1410

12G-SDI Bidirectional Transceiver



- 12G-SDI Fiber receiver and transmitter
- Supports 12G/6G/3G/1.5G/SD-SDI video standards
- Auto reclocking
- Bidirectional converter over Single Fiber Link
- Up to 10km (6.2 miles) @ 12Gbit/s
- Simplex LC/PC singlemode fiber connection

The OBD 1410 is a bidirectional Fiber to 12G-SDI transmitter and receiver which uses a simplex (single) fiber link. The kit includes two modules, Type A and Type B, with their power supplies, working together in a WDM closed-loop environment. Each channel is fully independent and can support different SDI video formats. The modules auto-detect and re-clock any video signal.

Model: OBD 1410

OTT 1414

4-Channel 12G-SDI to Fiber Transmitter



- 12G-SDI dual channel Fiber transmitter
- Supports 12G/6G/3G/1.5G/SD-SDI video standards
- Auto reclocking
- Up to 10km* (6.2 miles) @ 12G-SDI (singlemode)
- 2x Duplex LC/PC single-mode optical connection

The OTT 1414 is a compact 4-Channel 12G-SDI to fiber transmitter. It has four completely independent channels. Each will auto-detect and re-clock any source prior to optical transmission.

Models: OTT 1414, OTT 1414 CW

OTT 1412

2-Channel 12G-SDI to Fiber Transmitter



- 12G-SDI dual channel Fiber transmitter
- Supports 12G/6G/3G/1.5G/SD-SDI video standards
- Auto reclocking
- Up to 10km* (6.2 miles) @ 12G-SDI single-mode
- Duplex LC/PC single-mode optical connection

The OTT 1412 is a compact 2-Channel 12G-SDI to fiber transmitter. It has two completely independent channels. Each will auto-detect and re-clock any source prior to optical transmission.

Models: OTT 1412, OTT 1412 CW

OTX 1410

12G-SDI to Fiber Transmitter



- 12G-SDI Fiber transmitter
- Supports 12G/6G/3G/1.5G/SD-SDI video standards
- Auto reclocking
- Reclocked SDI loop out connection

The OTX 1410 is a compact 12G-SDI to fiber transmitter. Operation is fully automatic. The video format is automatically detected, reclocked and transmitted. A reclocked 12G-SDI output is available.

Models: OTX 1410 LC, OTX 1410 LC-40, OTX 1410 ST, OTX 1410 CW

ORR 1404

4-Channel Fiber to 12G-SDI Receiver



- 4-Channel 12G-SDI Fiber Receiver
- Four fully independent 12G-SDI channels.
- Supports 12G/6G/3G/1.5G/SD-SDI video standards
- Auto reclocking
- 1260nm to 1620nm wavelength input range
- 2x Duplex LC Single-mode fiber connection

The ORR 1404 is a compact 4-Channel Fiber receiver to 12G-SDI converter. It has four completely independent 12G-SDI channels. Each will autodetect and re-clock any video source prior to electrical conversion. It is compatible with CDWM and non-CWDM fiber types. As with all yellobrik modules, it is compatible with the RFR 1200 rack frame, which provides power redundancy.

Models: ORR 1404, ORR 1404 HS

ORR 1402

2-Channel Fiber to 12G-SDI Receiver



- 2-Channel 12G-SDI Fiber Receiver
- Two fully independent 12G-SDI channels.
- Supports 12G/6G/3G/1.5G/SD-SDI video standards
- Auto reclocking
- 1260nm to 1620nm wavelength input range
- Duplex LC Single-mode fiber connection

The ORR 1402 is a compact 2-Channel Fiber receiver to 12G-SDI converter. It has two completely independent 12G-SDI channels. Each will autodetect and re-clock any video source prior to electrical conversion. It is compatible with CDWM and non-CWDM fiber types. As with all yellobrik modules, it is compatible with the RFR 1200 rack frame, which provides power redundancy.

Models: ORR 1402, ORR 1402 HS

ORX 1400

Fiber to 12G-SDI Receiver



- Two independent inputs
- Three outputs per channel
- Suitable for SDI video up to 4k DCI / UHD
- Supports 12G/6G/3G/1.5G/SD-SDI video standards
- Reclocking
- Auto-detect input format

The ORX 1400 is a compact Fiber receiver to 12G-SDI converter. Operation is fully automatic. The video format is automatically detected, reclocked and provided on two 12G-SDI output connections. As with all yellobrik modules, it is compatible with the RFR 1200 rack frame, which provides power redundancy.

Models: ORX 1400 LC, ORX 1400 ST

OTT 1814

4-Channel 3G-SDI to Fiber Transmitter



- Supports 3G/1.5G/SD-SDI video standards
- 3G Level A and Level B support (all formats)
- Auto reclocking
- Up to 10km* (6.2 miles) @ 3Gbit/s
- 2x Duplex LC/PC single-mode connections

The OTT 1814 is a compact 4-Channel 3G-SDI to fiber transmitter.

It has four completely independent channels. Each will auto-detect and re-clock any source prior to optical transmission. The module is fully compatible with 3G Level A and Level B formats.

Models: OTT 1814, OTT 1814 CW

OTT 1812-1

2-Channel 3G-SDI to Fiber Transmitter



- Supports 3G/1.5G/SD-SDI video standards
- 3G Level A and Level B support (all formats)
- Auto reclocking
- Up to 10km* (6.2 miles) @ 3Gbit/s
- Duplex LC/PC single-mode optical connection

The OTT 1812-1 is a compact 2-Channel 3G-SDI to fiber transmitter.

It has two completely independent channels. Each will auto-detect and re-clock any source prior to optical transmission. The module is fully compatible with 3G Level A and Level B formats.

Models: OTT 1812-1, OTT 1812-1 CW

OTX 1812

3G-SDI to Fiber Transmitter



- Supports 3G/1.5G/SD-SDI video standards
- 3G Level A and Level B support (all formats)
- Auto reclocking
- Reclocked SDI loop out connection
- Versions for LC, ST or SC fiber connections
- Up to 10km* (6.2 miles) @ 3G-SDI(singlemode)
- Up to 300m* (984 feet) @ 3G-SDI(multimode)

The OTX 1812 is a compact 3G-SDI to fiber transmitter. Operation is fully automatic. The video format is automatically detected, reclocked and transmitted. A reclocked 3G-SDI output is available.

Models: OTX 1812 LC, OTX 1812 ST, OTX 1812 SC, OTX 1812 MM

ORR 1804

4-Channel Fiber to 3G-SDI Receiver



- Supports 3G/1.5G/SD-SDI video standards
- 3G Level A and Level B support
- Auto reclocking
- 1260nm to 1620nm wavelength input range
- 2x Duplex LC/PC single-mode fiber connections

The ORR 1804 is a compact 4-Channel Fiber receiver to 3G-SDI converter. It has four completely independent 3G-SDI channels. Each will autodetect and re-clock any video source prior to electrical conversion. It is compatible with CDWM and non-CWDM fiber types. As with all yellobrik modules, it is compatible with the RFR 1200 rack frame, which provides power redundancy.

Models: ORR 1804, ORR 1804 HS

ORR 1802-2

2-Channel Fiber to 3G-SDI Receiver



- 2-Channel 3G-SDI Fiber Receiver
- Supports 3G/1.5G/SD-SDI video standards
- 3G Level A and Level B support
- Auto reclocking
- 1260nm to 1620nm wavelength input range
- Duplex LC/PC single-mode optical connection

The ORR 1802 is a compact 2-Channel Fiber receiver to 3G-SDI converter. It has two completely independent 3G-SDI channels. Each will autodetect and re-clock any video source prior to electrical conversion. It is compatible with CDWM and non-CWDM fiber types. As with all yellobrik modules, it is compatible with the RFR 1200 rack frame, which provides power redundancy.

Model: ORR 1802-2 LC

ORX 1802-2

Fiber to 3G-SDI Receiver



- Supports 3G/1.5G/SD-SDI video standards
- 3G-SDI Level A and Level B support
- 2x Auto reclocking SDI outputs
- Versions for LC, ST or SC fiber connections
- Input range 1260nm to 1620nm single-mode
- Input range 780nm to 880nm multi-mode

The ORX 1802 is a compact Fiber receiver to 3G-SDI converter.

Operation is fully automatic. The video format is automatically detected, reclocked and provided on two 3G-SDI output connections.

As with all yellobrik modules, it is compatible with the RFR 1200 rack frame, which provides power redundancy.

Models: ORX 1802-2 LC, ORX 1802-2 SC, ORX 1802-2 ST, ORX 1802-2 MM

OTR 1814

4-Channel 3G-SDI to Fiber Transceiver



- Supports 3G / 1.5 G / SD-SDI video standards
- Auto reclocking
- Up to 10km* (6.2 miles) @ 3G-SDI single-mode
- Up to 300m* (984 feet) @ 3G-SDI multi-mode
- Error free optical transmission
- 2x Duplex LC optical connection

The OTR 1814 is a 4-channel fiber/SDI transceiver in a single 2RU, fanless package, enabling long-distance distribution of uncompressed 3G-SDI signals up to 2K DCI. Each unit has two independent TX/RX channels that automatically detect, relock, and transmit or receive SDI signals over fiber.

Models: OTR 1814, OTR 1814 MM, OTR 1814 CW

OTR 1810-1

3G-SDI to Fiber Transceiver



- 3G-SDI Fiber receiver and transmitter
- Supports 3G/1.5G/SD-SDI video standards
- Auto reclocking
- Up to 10km* (6.2 miles) @ 3G-SDI single-mode
- Up to 300m* (984 feet) @ 3G-SDI multi-mode
- Duplex LC optical connection

The OTR 1810-1 transceiver has an independent transmitter and receiver channel, which provide an effective solution for any 3G-SDI signal up to HD & 2K DCI. Operation of the receiver and transmitter is automatic. Video formats are automatically detected and relocked. It is compatible with the RFR 1200 rack frame, which provides power redundancy.

Models: OTR 1810-1 LC, OTR 1810-1 MM, OTR 1810 CW

OBD 1814

4-Channel 3G-SDI to Fiber Transceiver



- 4-Ch 3G-SDI Fiber Transceiver
- Supports 3G / 1.5 G / SD-SDI video standards
- Auto reclocking
- Bidirectional converter over Single Fiber Link
- Error-free optical connections
- Up to 10km (6.2 miles) @ 3Gbit/s
- 2x Simplex LC/PC single-mode fiber connection

The OBD 1814 is a 4-Channel Bidirectional Fiber to 3G-SDI transmitter and receiver which uses two single fiber links supplied in a compact self contained package. It conveniently fit within 2RU height.

The kit includes two modules with their power supplies, Type A and Type B, working together in a WDM closed loop environment.

Each module has two 3G-SDI input and output. It uses a pair of Simplex (single fiber) links between the two devices. Each channel is fully independent and can support different standards and formats of SDI video. The modules auto-detect and re-lock any video signal.

Model: OBD 1814

OBD 1810-2

3G-SDI Bidirectional Transceiver



- 3G-SDI Fiber receiver and transmitter
- Supports 3G / 1.5 G / SD-SDI video standards
- Auto reclocking
- Bidirectional converter over single fiber link
- Up to 10km* (6.2 miles) @ 3Gbit/s
- Simplex LC/PC single-mode fiber connection

The OBD 1810-2 is a bidirectional Fiber to 3G-SDI transmitter and receiver which uses a simplex (single) fiber link. The kit includes two modules, Type A and Type B, with their power supplies, working together in a WDM closed-loop environment.

Each channel is fully independent and can support different SDI video formats. The modules auto-detect and re-clock any video signal.

Model: OBD 1810-LC

OTR 1210

MADI Coax to Fiber Transceiver



- MADI Optical to MADI Coaxial converter
- 64 Audio Channels (IN and OUT)
- Real time conversion with no degradation
- Up to 10km (6.2 miles) with Single-mode fiber
- Up to 2km (1.2 miles) with Multi-mode fiber
- Duplex LC fiber connections

The OTR 1210 is a MADI fiber transmitter and receiver combined in a single package. The module is designed to convert up to 64 audio channels Bidirectionally (64 In & 64 Out) between MADI Optical and MADI Coaxial formats. The conversion is done in real time (no latency) and does not degrade the signal quality. The OTR 1210 is a compact solution to extend the reach of MADI audio over long distances.

Models: OTR 1210, OTR 1210 MM-850, OTR 1210 MM-1310, OTR 1210 CW

OBD 1210

MADI Coax to Fiber Transceiver



- Bidirectional converter over Single Fiber Link
- Supports up to 64 Channels of Audio I/O
- Real-time conversion with no degradation
- Closed loop WDM fiber system
- Up to 10km (6.2 miles) over single-mode fiber

The OBD 1210 is a compact matched pair of MADI fiber transceivers that extends MADI signals up to 10km. It converts up to 64 Bidirectional audio channels between MADI Optical and Coaxial formats in real time, without latency or signal loss, using a single-mode simplex fiber link.

The kit includes two modules, Type A and Type B, with their power supplies, designed to operate together in a WDM closed-loop environment.

Model: OBD 1210

OCM 1841/OCM 1842/OCM 1843/OCM 1844

4 Channel CWDM Mux/Demux

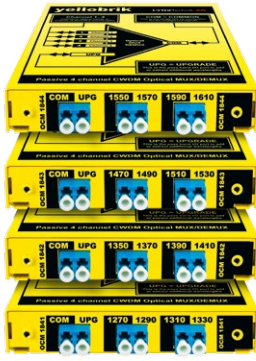

- Mux/DeMux 4 Channels over a Single Fiber
- Passive Device (no power required)
- Combine all four modules for up to 16 Channels
- Compatible with 1/2RU RFR 1018 rack frame

The OCM 1841, OCM 1842, OCM 1843, OCM 1844 are CWDM 4-Channel optical multiplexers / demultiplexers designed to send and receive up to 4 individual signals over a single fiber link. Each module has an upgrade port to cascade into the other 4-Channel modules, expanding the capability of the system to a maximum of 16 channels.

The modules can be used standalone or integrated into the RFR 1018 rack frame.

Models: OCM 1841, OCM 1842, OCM 1843, OCM 1844

OCM 1891/OCM 1892

9 Channel CWDM Mux/Demux



- Mux/DeMux 9 Channels over a Single Fiber
- 1270nm to 1430nm (ITU-T G.694.2)
- Passive Device (no power required)
- Combine both for 18-Channel solution
- Compatible with 1/2RU RFR 1018 rack frame

The OCM 1891 is a CWDM 9-Channel optical multiplexer / demultiplexer designed to send or receive up to 9 individual signals over a single fiber link. The module has an upgrade port to connect to the OCM 1892, which expands the capability of the modules to 18 CWDM channels.

The modules can be used standalone or integrated into the RFR 1018 rack frame.

Models: OCM 1891, OCM 1892

OSP 1812/OSP 1812M/OSP 1814

Passive Optical Splitters

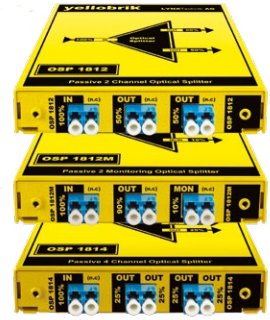

- Optical Splitter / Combiner
- 50/50 split ratio
- Passive Device (no power required)
- Single-mode, LC connectors
- Optional 1/2RU 19" rack frame (RFR 1018)

The OSP 1812, OSP 1812 M and OSP 1814 are compact optical yellobriks used to split or combine optical signals.

OSP 1812: One input and two outputs (each 50%)

OSP 1812 M: One input and two outputs, one at 90% power and a second at 10% power. Typically used as a monitoring output.

OSP 1814: One input and four outputs (each 25%)

Models: OSP 1812, OSP 1812 M, OSP 1814

OCM 1800

19 Channel CWDM Mux/Demux 1270nm-1610nm

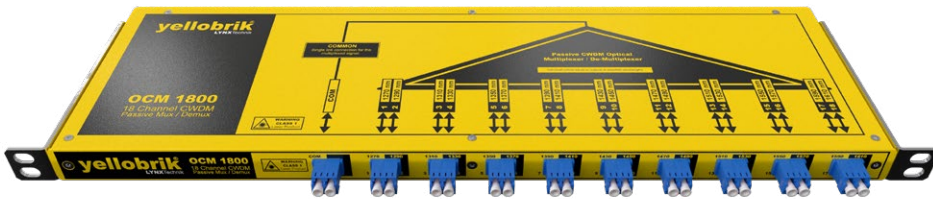

- Mux/DeMux 18 Channels over a Single Fiber
- 1270nm to 1610nm (ITU-T G.694.2)
- Passive Device (no power required)
- Combines with 9 or 4-Channel OCMs
- 1/2RU Self mounted

The OCM 1800 is a 1/2RU CWDM 18-Channel optical multiplexer / demultiplexer designed to send or receive up to 18 individual signals over a single fiber link. This module is fully compatible with other LYNX Technik OCMs. It can be rack mounted without the need for additional component using the rack ears provided.

Model: OCM 1800

OSW 1022

2x2 Optical Switch



- Compatible with CWDM and DWDM
- Non-latching and latching mode
- 2x GPI for path selections
- 2x GPO for connection path monitoring
- Local control and Status LED on the device
- Singlemode fiber connection with LC connector

The OSW 1022 is a 2x2 optical switch that connects two fiber pairs, enabling passive path selection via GPI, local DIP switches, or remote software. GPIs and GPOs support control and monitoring. It is ideal for applications such as emergency switchover, route diversity, system protection, and network reconfiguration.

Model: OSW 1022

18 Channel Optical Multiplexing / De-Multiplexing

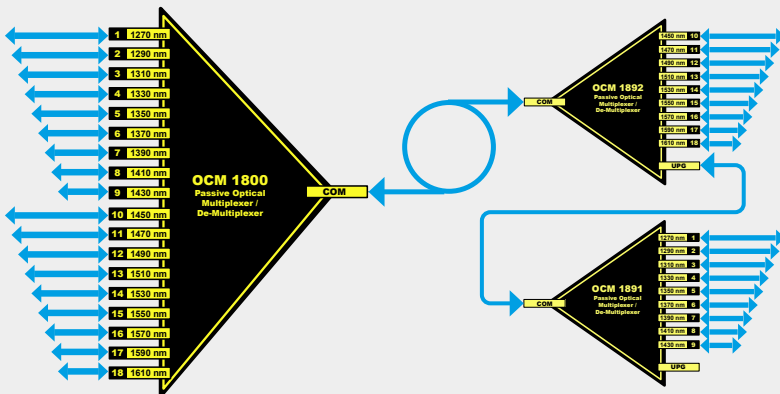

OTR 1A41 / OTR 1A42

8K Fiber Transmission System



- 4-Channel 12G/6G/3G /1.5G /SD-SDI Transport
- Transport 4x4K or 1x8K up to 10km (6.2 miles)
- Wavelengths 1A41: 1270, 1290, 1310 and 1330nm
- Wavelengths 1A42: 1350, 1370, 1390 and 1410nm
- Each channel is individually reclocked
- Integrated upgrade port
- Kit includes transmitter, receiver and power

The OTR 1A41 is a self-contained fiber kit for transmitting four independent 12G-SDI signals (or 8K/48G) over a single fiber, including transmitter, receiver, and power supplies. Each channel auto-detects and re-clocks any SDI format up to 12G, and 8K signals use four 12G links at 60fps. An expansion port allows adding four more channels via the OTR 1A42, with LED indicators for power and signal. Up to four modules can be mounted in a 1/2 RU RFR 1018 tray.

Models OTR 1A41: OTR 1A41(OTX 1A41 & ORX 1A41), OTR 1A41 SC (OTX 1A41 SC & ORX 1A41 SC)

Models OTR 1A42: OTR 1A42 (OTX 1A42 & ORX 1A42), OTR 1A42 SC (OTX 1A42 SC & ORX 1A42 SC)

OTR 1441 / OTR 1442

4k Fiber Transmission System



- 4-Channel 3G / 1.5G / SD-SDI Transport system
- Transport 4xHD or 1x4K up to 20km (12 miles)
- Wavelengths 1441: 1270, 1290, 1310 and 1330nm
- Wavelengths 1442: 1350, 1370, 1390 and 1410nm
- Each channel is individually reclocked
- Integrated upgrade port
- Kit includes transmitter, receiver and power

The OTR 1441 is a self-contained fiber kit for transmitting four independent 3G-SDI signals (or 4K/12G) over a single fiber up to 20km, including transmitter, receiver, and power supplies. It supports full 4K at 60fps, auto-detects and reclocks SDI bitrates up to 3G, and provides LED indicators for power and signal.

Models OTR 1441: OTR 1441(OTX 1441 & ORX 1441), OTR 1441 SC (OTX 1441 SC & ORX 1441 SC)

Models OTR 1442: OTR 1442 (OTX 1442 & ORX 1442), OTR 1442 SC (OTX 1442 SC & ORX 1442 SC)

RCT 1012

yellobrik Rack Controller



- Control/Monitor/Configure up to 12 yellobriks
- 12x USB-A, 1x RJ45 1GbE
- SRV 1000 compatible to access module settings
- 4x GPI connections for power supply monitoring
- LED for Power, Overcurrent and High temperature

The RCT 1012 is a compact yellobrik rack controller that centralizes USB control for up to 12 devices via Ethernet, supporting automatic detection, hierarchical device management, bulk firmware updates, power monitoring, and, when paired with an SRV 1000, Auto-Control and SNMPv2 for remote monitoring via Lynx-Centraal.

Model: RCT 1012

SRV 1000

yellobrik Server Module



- Supports up to 256 yellobrik RCT 1012
- Enables AutoControl and Custom Control
- Facilitates system wide backups and restore
- Enables SNMP v2 for 3rd party control

The SRV 1000 is a yellobrik server module that simplifies multi-device management, enabling LynxCentraal features like automation, backup/restore, custom control panels, centralized updates, SNMPv2, and remote control, and can manage multiple RFR 1200 rack frames with one RCT 1012 controller per frame.

Model: SRV 1000

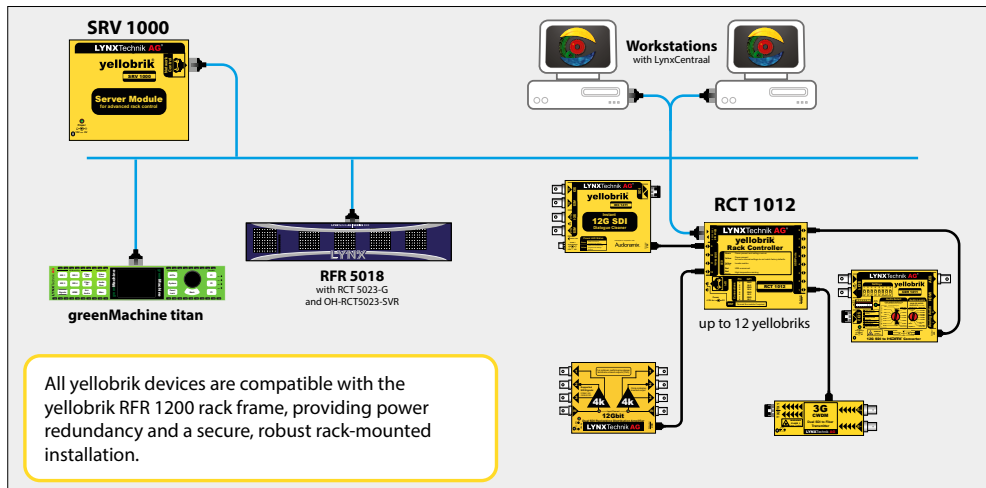

RFR 1200

19" Rack frame for yellobriks



- Compact 1 RU design
- Will accommodate up to 14 yellobriks
- External 12V DC power inputs
- Dual power inputs (Primary and Secondary)
- Power failure alarm GPI outputs
- Adjustable 19" mounting brackets to recess frame

The RFR 1200 is a compact mounting frame designed for yellobriks. Up to 14 yellobriks can be mounted vertically and mechanically clamped in place. Each slot has its own integrated power connector on a central power bus which can supply up to 200W of total power. Unscrew the spacer bracket to mount double slot modules like the PEC 1464, IDC 1411 or CDE 1922.

The rack has two external 12VDC inputs. "Power 1" is the primary power source, "Power 2" is the redundant backup. Status LEDs on the front panel indicate power supply health. The GPO connections can trigger alarms in the event of a power failure.

Remote Control and Monitoring

Use an RCT rack controller to automatically detect connected devices and displays them in Lynx Centraal for easy management. It supports bulk firmware updates and simplifies configuration of all connected modules via Ethernet.

The SRV 1000 adds extra management features such as Backup & Restore, Custom control and Auto Control.



Rack Extensions for Mounting Power Supplies

To ensure secure installation of LynxTechnik power supplies, rack extensions (RXT) are available for standard 19-inch racks.

The RXT A100 and RXT A200 can extend the RFR 1200 rack ears or be installed independently elsewhere in the bay.



RXT A200 with RPS A200 installed flush as a standalone power supply holder.



RXT A200 with RPS A200



RXT A100 with RPS A100

RFR 1018

19"/0.5RU mounting tray



- Small footprint only 0.5 RU High x 19" Rack mount
- Easy module mounting - no tools needed
- Combine with RFR 1200 frame for system use

RFR 1001

Single yellobrik mounting bracket



- Robust metal mounting bracket
- Mount on any flat surface
- Ideal for mounting on 19" rack rails
- No tools needed for module installation

Appendix I: Power Supply Holder

RXT 1001

Power supply holder for RFR 1200



- Accommodates 1 power supply
- Innovative locking system to secure power supply
- Compatible with RPS 1120, RPS 6120, and RPS A100 power supplies

RXT A100

Power supply holder for RPS A100



- Accommodates 1 power supply
- Innovative locking system to secure power supply
- Compatible with RPS A100 power supplies

RXT A200

Power supply holder for RPS A200

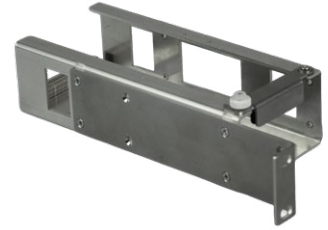

- Accommodates 1 power supply
- Innovative locking system to secure power supply
- Compatible with RPS A200 power supplies

Appendix II: Power Adapter Options

P-TAP 1000



Use with a standard battery P-TAP power source.

Technical Specifications

Physical	Length(incl. connectors): 2m (6.5 feet)
Connectors	P-Tap Male / Barrel Con.(ø 5.5mm/L:7mm)
Model #	P-Tap 1000

XLR 1000



Use with standard 4 pin XLR camera battery power source.

Technical Specifications

Physical	Length(incl. connectors): 1.9m (6.2 feet)
Connectors	4 Pin XLR / Barrel Con.(ø 5.5mm/L:7mm)
Model #	XLR 1000

Appendix III: Power Supplies

RPS A200

12V/200W AC to DC Desktop Power Supply

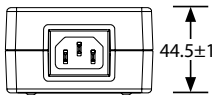
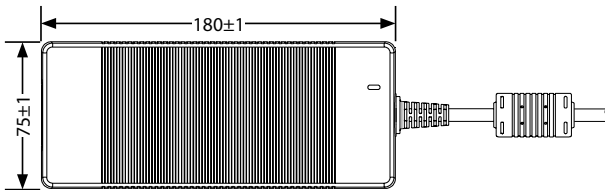

44.5±1

Note:
1. Measurements are in mm
2. Net weight: approx. 950g



- Supplies 12V/16.67A via Molex connector
- Operating Voltage 100 to 240V AC / 50-60 Hz
- Max. 200W Output Power
- Short Circuit, OverVoltage and Over Current Protection
- Active Power Factor Correction (PFC) function
- Energy efficiency level VI or CoC Tier II

Safety Standards



RPS A100

12V/100W AC to DC Desktop Power Supply

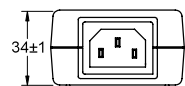
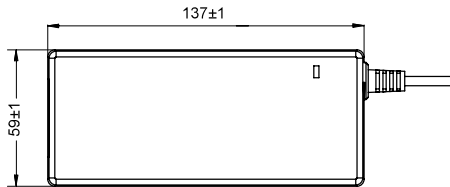

34±1

Note:
1. Measurements are in mm
2. Net weight: approx. 450g



- Wide Operating Voltage 100 to 240V AC, 50 to 60 Hz
- 100W Output Power
- Active Power Factor Correction (PFC) function
- Energy efficiency level VI or CoC Tier II
- LED indicator for Power on

Safety Standards



RPS 1018

18W DC Power supply (12V/1.5A)

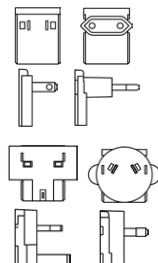
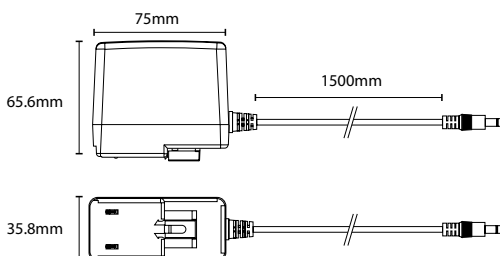



- Wide Operating Voltage 100 to 240 VAC, 50 to 60 Hz
- Single Output 18W
- Interchangeable Plug
- DoE Level VI, Energy Star, ErP Stage 2 CoC Tier 2, NRCAN, GEMS Level VI
- CCC, UK CA, TÜV, UL, RoHS, CE and FCC Certified

Appendix IV: Fiber Adapter Options

LYNXTechnik offers wide support of varying optical connections with yellobriks that support the usage of SFP modules. Whether you're using LC/PC, ST/PC, or SC/PC Connections, we've got you covered.

Sometimes though certain modules are just available as one type of optical connector. For this, we're offering broadcast-quality optical adapter kits. These adapter kits allow the use of ST, SC, and FC fiber connections on the module. These are SMF, have a length of 0.5m (19.6"), and introduce less than 0.25dB attenuation. Each kit is measured and has the precise attenuation printed on the packaging it comes with.

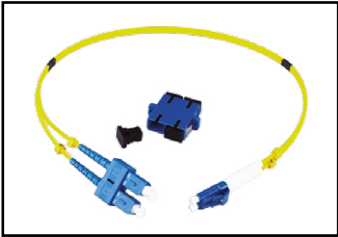
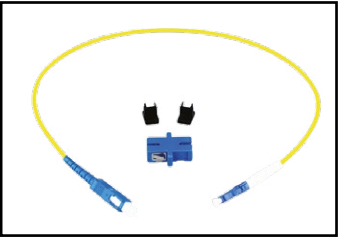
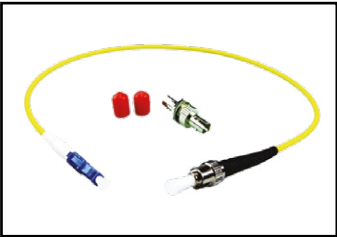
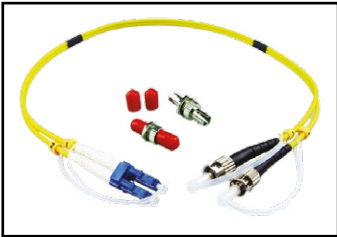
All kits are available as Simplex (SIM) and Duplex (DUP) variants.

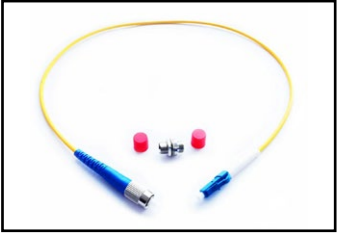
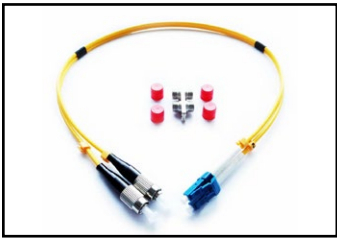
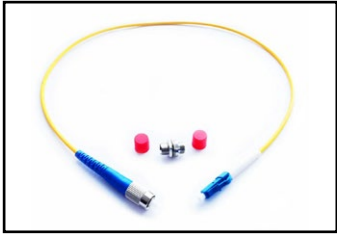
<p>LC/SC DUP</p> <p>Duplex LC/PC to SC/PC Adapter</p>  <p>Technical Specifications</p> <p>Attenuation <0.25dB</p> <p>Physical Length: 0.5m (19")</p> <p>Connectors LC/PC, SC/PC (Duplex)</p> <p>Model # LC/SC DUP</p>	<p>LC/SC SIM</p> <p>Simplex LC/PC to SC/PC Adapter</p>  <p>Technical Specifications</p> <p>Attenuation <0.25dB</p> <p>Physical Length: 0.5m (19")</p> <p>Connectors LC/PC, SC/PC (Simplex)</p> <p>Model # LC/SC SIM</p>	<p>LC/ST DUP</p> <p>Duplex LC/PC to ST/PC Adapter</p>  <p>Technical Specifications</p> <p>Attenuation <0.25dB</p> <p>Physical Length: 0.5m (19")</p> <p>Connectors LC/PC, ST/PC (Duplex)</p> <p>Model # LC/ST DUP</p>	<p>LC/ST SIM</p> <p>Simplex LC/PC to ST/PC Adapter</p>  <p>Technical Specifications</p> <p>Attenuation <0.25dB</p> <p>Physical Length: 0.5m (19")</p> <p>Connectors LC/PC, ST/PC (Simplex)</p> <p>Model # LC/ST SIM</p>
<p>LC/FC DUP</p> <p>Duplex LC/PC to FC/PC Adapter</p>  <p>Technical Specifications</p> <p>Attenuation <0.25dB</p> <p>Physical Length: 0.5m (19")</p> <p>Connectors LC/PC, FC/PC (Duplex)</p> <p>Model # LC/FC DUP</p>	<p>LC/FC SIM</p> <p>Simplex LC/PC to FC/PC Adapter</p>  <p>Technical Specifications</p> <p>Attenuation <0.25dB</p> <p>Physical Length: 0.5m (19")</p> <p>Connectors LC/PC, FC/PC (Simplex)</p> <p>Model # LC/FC SIM</p>	<p>LC/LC DUP</p> <p>Duplex LC/PC Patch Cable</p>  <p>Technical Specifications</p> <p>Attenuation <0.25dB</p> <p>Physical Length: 0.5m (19")</p> <p>Connectors LC/PC (Duplex)</p> <p>Model # LC/LC DUP</p>	<p>LC/LC SIM</p> <p>Simplex LC/PC Patch Cable</p>  <p>Technical Specifications</p> <p>Attenuation <0.25dB</p> <p>Physical Length: 0.5m (19")</p> <p>Connectors LC/PC (Simplex)</p> <p>Model # LC/FC SIM</p>

Appendix V: SFP Options

Table: R1 - 3G-SDI Receiver SFPs			Type	Sensitivity						
				3G		1.5G				
OH-RX-1-LC/SC/ST	3G-SDI Singlemode LC/SC/ST Fiber RX	10km (1260 - 1620nm)	Simplex	-18dBm						
OH-RX-8-LC	3G-SDI Singlemode LC Fiber RX	80km (1260 - 1620nm)	Simplex	-26dBm						
OH-RX-0-850-MM	3G-SDI Multimode LC Fiber RX	550m (780 - 880nm)	Simplex	-15dBm	-16dBm					
OH-RR-1-LC	3G-SDI Singlemode LC Fiber RX/RX	10km (1260 - 1620nm)	Duplex	-18dBm						
OH-RR-8-LC	3G-SDI Singlemode LC Fiber RX/RX	80km (1260 - 1620nm)	Duplex	-26dBm						
Table: R2 - 12G-SDI Receiver SFPs			Type	Sensitivity						
				12G	6G	3G	1.5G			
OH-RX-12G-LC	12G-SDI Singlemode LC Fiber RX	10km (1260 - 1620nm)	Simplex	-10dBm	-14dBm		-16dBm			
OH-RX-12G-ST	12G-SDI Singlemode ST Fiber RX	10km (1260 - 1620nm)	Simplex	-10dBm		-14dBm				
OH-RX-4-12G-LC	12G-SDI Singlemode LC Fiber RX	40km (1260 - 1620nm)	Simplex	-18dBm						
OH-RX-12G-SDI	12G-SDI Singlemode micro BNC RX	10km (1260 - 1620nm)	1-Ch							
OH-RR-12G-LC	12G-SDI Singlemode LC Fiber RX/RX	10km (1260 - 1620nm)	Duplex	-9dBm	-10dBm					
OH-RR-4-12G-LC	12G-SDI Singlemode LC Fiber RX/RX	40km (1260 - 1620nm)	Duplex	-18dBm						
Table: T1 - 3G-SDI Transmitter SFPs			Type	Power						
				Min.	Typ.	Max.				
OH-TX-1-LC/ST/SC	3G-SDI Singlemode LC / ST / SC Fiber TX	10km (1310nm)	Simplex	-5dBm						
OH-TX-4-12G-LC	3G-SDI Singlemode LC / ST Fiber TX	40km (1310nm)	Simplex	3dBm						
OH-TT-1-LC	3G-SDI Singlemode LC Fiber TX/TX	10km (1270 ... 1610nm)	Duplex	-8dBm	-	-3dBm				
Table: T2 - 12G-SDI Transmitter SFPs			Type	Power						
				Min.	Typ.	Max.				
OH-TX-12G-LC/ST	12G-SDI Singlemode LC / ST Fiber TX	10km (1310nm)	Simplex	-0.5dBm						
OH-TT-12G-LC	12G-SDI Singlemode LC Fiber TX/TX	10km (1270 ... 1610nm)	Duplex	-5.5dBm	-	+0.5dBm				
OH-TT-12G-SDI	12G-SDI Singlemode micro BNC TX/TX	(1270 ... 1610nm)	2-Ch							
Table: T3 - 3G-SDI CWDM Transmitter SFPs			Type	Power						
				Min.	Typ.	Max.				
OH-TX-4-XXXX-LC	3G-SDI Singlemode LC Fiber TX	40km (1270 ... 1610nm)	Simplex	-4dBm	-	+2dBm				
OH-TT-4-XXXX-XXXX-LC	3G-SDI Singlemode LC Fiber TX/TX	40km (1270 ... 1610nm)	Duplex	-4dBm	-	+2dBm				
OH-TT-8-XXXX-XXXX-LC	3G-SDI Singlemode LC Fiber TX/TX	80km (1270 ... 1610nm)	Duplex	+1dBm	-	+5dBm				
Table: T4 - 12G-SDI CWDM Transmitter SFPs			Type	Power						
				Min.	Typ.	Max.				
OH-TX-12G-XXXX-LC	12G-SDI Singlemode LC Fiber TX	10km (1270 ... 1610nm)	Simplex	-2dBm	-	+3dBm				
OH-TX-4-12G-XXXX-LC	12G-SDI Singlemode LC Fiber TX	10km (1270 ... 1610nm)	Simplex	0dBm	-	+5dBm				
OH-TT-12G-XXXX-XXXX-LC	12G-SDI Singlemode LC Fiber TX/TX	10km (1270 ... 1610nm)	Duplex	-2dBm	-	+3dBm				
Table: TR1 - 3G-SDI Transceiver SFPs			Type	Power			Sensitivity			
				Min.	Typ.	Max.	3G	1.5G		
OH-TR-1-LC	3G-SDI Singlemode LC Fiber TX/RX	10km	Duplex	-5dBm			-16dBm			
OH-TR-0-850-MM	3G-SDI Multimode LC Fiber TX/RX	550m	Duplex	-5dBm			-15dBm			
OH-TR-SDI	3G-SDI micro BNC TX/RX		2-Ch							
Table: TR2 - 12G-SDI Transceiver SFPs			Type	Power			Sensitivity			
				Min.	Typ.	Max.	12G	6G	3G	1.5G
OH-TR-12G-LC	12G-SDI Singlemode LC Fiber TX/RX	10km	Duplex	-5dBm	-	+0.5dBm	-10dBm	-14dBm		
OH-TR-12G-LC	3G-SDI micro BNC TX/RX		2-Ch							
OH-BD-12G-1270-LC	12G-SDI Singlemode LC Fiber TX/RX	10km (TX: 1270nm RX: 1330nm)	Simplex	-3dBm	-	+3dBm	-10dBm	-14dBm		
OH-BD-12G-1330-LC	12G-SDI Singlemode LC Fiber TX/RX	10km (TX: 1330nm RX: 1270nm)	Simplex	-3dBm	-	+3dBm	-10dBm	-14dBm		
Table: TR3 - 3G-SDI CWDM Transceiver SFPs			Type	Power			Sensitivity			
				Min.	Typ.	Max.	3G	1.5G		
OH-TR-4-XXXX-LC	3G-SDI Singlemode LC Fiber TX/RX	40km (TX: 1270 ... 1610nm)	Duplex	-4dBm	-	+2dBm	-20dBm			
OH-TR-8-XXXX-LC	3G-SDI Singlemode LC Fiber TX/RX	80km (TX: 1270 ... 1610nm)	Duplex	+1dBm	-	+5dBm	-28dBm			
Table: TR4 - 12G-SDI CWDM Transceiver SFPs			Type	Power			Sensitivity			
				Min.	Typ.	Max.	12G	6G	3G	1.5G
OH-TR-12G-XXXX-LC	12G-SDI Singlemode LC Fiber TX/RX	10km (TX: 1270 ... 1610nm)	Duplex	-2dBm	-	+3dBm	-10dBm	-14dBm		
Table: TR5 - MADI Transceiver SFPs			Type	Power			Sensitivity			
				Min.	Typ.	Max.	3G	1.5G		
OH-TR-MADI-1310 MM	MADI Singlemode TX (1310nm) Multimode RX (850-1310nm) LC Fiber	550m	Duplex	-20dBm	-	-14dBm	-30dBm			
Table: TRE1 - 1GbE Transceiver SFPs			Type	Data Rates	Power		Sensitivity			
					Min.	Typ.	Max.			
OH-TR-51-LC	1GbE Singlemode LC Fiber TX/RX	10km	Duplex	1.25GbE, 1GbE	-3 dBm		-23dBm			
OH-TR-50-850-MM	1GbE Singlemode LC Fiber TX/RX	550m (TX: 850nm / RX: 780 - 880nm)	Duplex	1.25GbE, 1GbE	-2dBm	-	-7dBm	-15dBm		
OH-BD-51-1310-LC	1GbE Singlemode LC Fiber	20km (TX: 1310nm / RX: 1550nm)	Simplex	1.25GbE, 1GbE	-9dBm	-	-3dBm			
OH-BD-51-1550-LC	1GbE Singlemode LC Fiber	20km (TX: 1550nm / RX: 1310nm)	Simplex	1.25GbE, 1GbE	-9dBm	-	-3dBm			
Table: TRE2 - 10GbE Transceiver SFPs			Type	Data Rates	Power		Sensitivity			
					Min.	Typ.	Max.			
OH-TR-10G-LC	10GbE Singlemode LC Fiber TX/RX	20km	Duplex	10GbE, 1GbE	-3dBm	-	+1dBm	-14.4 dBm		
OH-TR-10G-LC-MM	10GbE Multimode LC Fiber TX/RX	550m (TX: 850nm / RX: 780 - 880nm)	Duplex	10GbE, 1GbE	-6dBm	-	-1dBm	-11 dBm		
OH-TR-10G-RJ45	10GbE Electrical RJ45	30m	RJ45	10GbE, 1GbE						
OH-BD-10G-1330-LC	10GbE Singlemode LC Fiber	20km (TX: 1270nm / RX: 1330nm)	Simplex	10GbE, 1GbE	+1dBm	-	+5dBm	-15 dBm		
OH-BD-10G-1270-LC	10GbE Singlemode LC Fiber	20km (TX: 1330nm / RX: 1270nm)	Simplex	10GbE, 1GbE	+1dBm	-	+5dBm	-15 dBm		
Table: TRE3 - 1GbE CWDM Transceiver SFPs			Type	Data Rates	Power		Sensitivity			
					Min.	Typ.	Max.			
OH-TR-54-XXXX-LC	1GbE Singlemode LC Fiber TX/RX	40km (1270 ... 1610nm)	Duplex	1.25GbE, 1GbE	-5dBm	-	0dBm	-23dBm		
OH-TR-58-XXXX-LC	1GbE Singlemode LC Fiber TX/RX	80km (1270 ... 1610nm)	Duplex	1.25GbE, 1GbE	0dBm	-	+5dBm	-23dBm		
Table: TRE4 - 10GbE CWDM Transceiver SFPs			Type	Data Rates	Power		Sensitivity			
					Min.	Typ.	Max.			
OH-TR-10G-XXXX-LC	10GbE Singlemode LC Fiber	40km (1270 ... 1610nm)	Duplex	10GbE, 1GbE	0dBm	-	+4dBm	-23 dBm		

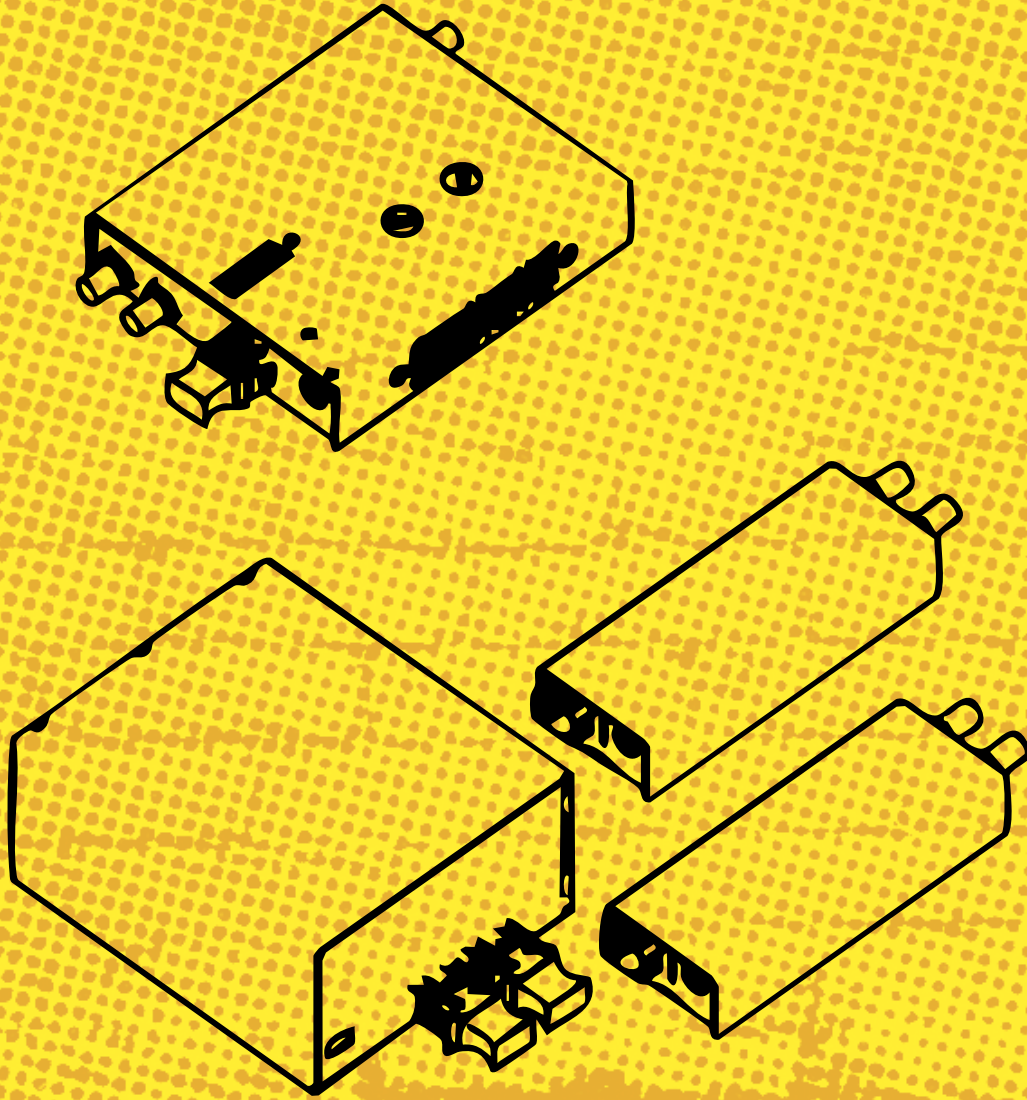

European Headquarters

LYNX Technik AG

Brunnenweg 3
D-64331 Weiterstadt
Germany

Phone: + 49 (0) 6150 1817 0
Fax: + 49 (0) 6150 1817 100
Email: info@lynx-technik.com

APAC Headquarters

LYNX Technik Pte Ltd

114 Lavender Street
#05-92 CTHub2
Singapore 338729

Phone: + 65 6702 5277
Fax: + 65 6385 5221
Email: infoasia@lynx-technik.com

USA Headquarters

LYNX Technik USA

26366 Ruether Ave
Santa Clarita, CA 91350
USA

Phone: (661) 251 8600
Fax: (661) 251 8088
Email: info@lynx-usa.com

Need assistance?



ticket.lynx-technik.com

www.lynx-technik.com



lynx-technik-ag



lynxtechnikag

Visit our Website



lynx-technik.com/yellobrick/