

4 Channel Analog Audio Embedder / De-embedder

Description

The P DM 5340 is a versatile 4 channel analog audio embedder or de-embedder, which can be used to address a variety of audio issues in broadcast. The module offers multi-format SDI support up to 3Gbit/s (auto-detect).

The module can be switched between a 4 channel embedder or de-embedder, or used as a combination of both. 16 channels of audio are always de-embedded from the SDI input signal and passed into an audio processing stage. In embedder mode, 4 channels of external audio are passed into the audio processing stage. Audio processing includes adjustable gain, phase invert and mute for all 20 channels as well as a selectable mono mixdown function for each left and right pair.

The processed audio is passed into further crossbars where the audio for the embedder, and / or audio for the external outputs can be user mapped.

Microprocessor control and on-board Flash RAM enable configurations and settings to be stored within the module.

Remote control, status monitoring and error reporting is possible with the LYNX APPolo Control System.

Features

- Supports SDI formats up to 3Gbit (auto-detect)
- Switch between 4 channel embedder or de-embedder
- 20 channel audio processing stage with adjustable gain, phase invert, mute and stereo to mono mixdown. Also provides overload and silence detection
- 20 x 4 mono output crossbar for external audio channel assignment
- 20 x 16 mono crossbar for embedder audio assignments
- Remote control, status monitoring and error reporting possible with the LYNX APPolo control system
- Full SNMP support when used with master controller option
- Hot swappable

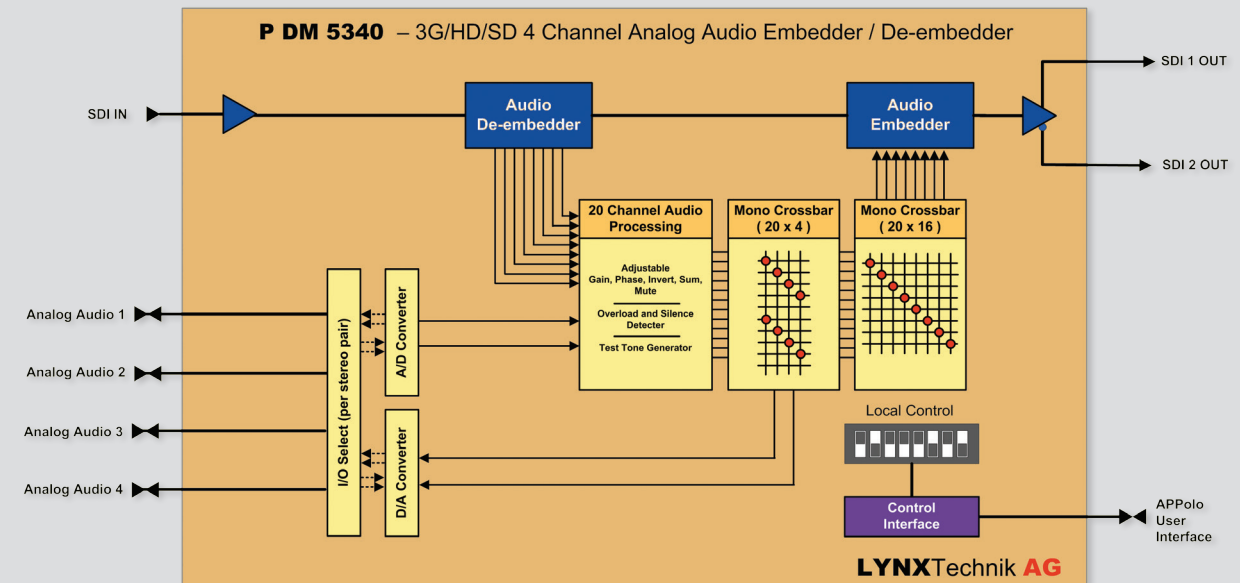
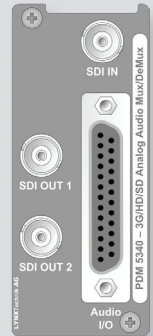
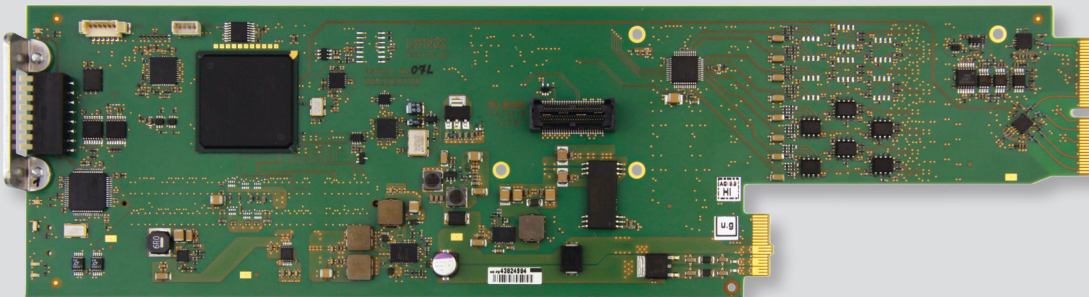

4 Channel Analog Audio Embedder / De-embedder

CardModules

Specifications

Video Input

Signal type	Serial digital video SMPTE, 292M, 424M, 259M with automatic video format and standard detection
Supported formats	SDI formats up to 3Gbit/s* (see table)
No. of inputs	1
Input impedance	75 Ohms
Connector	BNC
Return loss	> 15dB (270Mbit) > 10dB (2.97Gbit)

Video Outputs

No. of outputs	2
Signal type	Serial digital video SMPTE, 292M, 424M, 259M
Output format	Follows input format
Connector	BNC
Impedance	75 Ohm
Timing jitter	< 0.2UI (270Mbit) < 1.0UI (1.48Gbit) < 2.0UI (2.97Gbit)
Alignment jitter	< 0.2UI (270Mbit) < 0.2UI (1.48Gbit) < 0.3UI (2.97Gbit)
Return loss	> 15dB (270Mbit), >10dB (2.97Gbit)

Analog Audio I/O

No. of inputs / outputs	4 x analog audio inputs or 4 x analog audio outputs
Signal type	Balanced Analog Audio
Connector	Female 25pin SubD
Output impedance	150 Ohm
Input impedance	>10K Ohm
0 dB full scale range	Selectable: 12, 15, 18, 20, 22, 24 dBU full scale level

Audio Processing

De-embedder	All 16 audio channels are de-embedded from input SDI
Processing functions	20 channel adjustable: gain, Phase, Invert, Mute, Sum plus overload and silence detection.
Crossbars	24 x 8 channel (mono) output select crossbar 24 x 16 channel (mono) embedder select crossbar I/O select matrix to configure analog inputs and outputs
A/D quantization	24 bit
Sampling rate	48 kHz

Performance

Cable equalization	Up to 250m (820ft) using Belden 8281 (270Mbit) Up to 140m (459ft) using Belden 1694A (1.48Gbit) Up to 80m (262ft) using Belden 1694A (2.97Gbit)
Control	Basic local configuration using dip switch Full remote control / status monitoring possible when using the LYNX APPolo control system
Status monitoring	Module edge LED indicators

Electrical Specifications

Operating voltage	12 VDC
Power consumption	< 10W
Safety	IEC 60950/ EN 60950/VDE 0805

Mechanical

Size	283mm x 78mm
Weight	CardModule 120g, (4.2oz) connector plate 50g (1.8oz)

Ambient

Temperature	5°C to 40°C (41°F - 104°F) Maintaining specifications
-------------	---

Specifications subject to change

Settings and Control

Local Settings

Local control	ON/OFF (Dip Switch)
Embed audio group 1	ON/OFF (Dip Switch)
Embed audio group 2	ON/OFF (Dip Switch)
Embed audio group 3	ON/OFF (Dip Switch)
Embed audio group 4	ON/OFF (Dip Switch)
H-Blank	ON/OFF (Dip Switch)
V- Blank	ON/OFF (Dip Switch)

Additional Settings Available from APPolo Control System

Audio I/O port configuration
Audio shuffling (mono crossbar)
Audio processing

On Board Indicators / LEDs

General status / alarm LED - (visible with rack door closed)
SDI status LED
Audio status LED
Power status LED

* Supported Video Standards

Bits / color	10 Bit / 4:2:2 (Y,Cr,Cb)
Formats : SDTV	525 / 59.94Hz, 625 /50Hz
Formats : 1.5 Gbit	720p / 60 / 59.94 / 50 / 30 / 29.97 / 25 / 24 / 23.98 Hz 1080i / 60 / 59.94 / 50 Hz 1080p / 30 / 29.97 / 25 / 24 / 23.98 Hz 1080psF / 25 / 24 / 23.98 Hz
Formats : 3.0 Gbit	1080p / 60 / 59.94 / 50 Hz (Level A)

Options



RBO 5025 - Audio Adapter PCB

This option facilitates simplified connections of balanced analog audio I/O to the P DM 5340 modules SubD 25 pin connector.

Ordering Information

Model #	Description	Includes
P DM 5340	3G/HD/SD 4 Channel Analog Audio Embedder / De-embedder	CardModule, Rear termination Panel and Reference Manual (on CD)