

3Gbit Quad SDI Fiber Optic Transmitter

Description

The OTX 5840 is a flexible four channel SDI electrical to optical converter suitable for SDI/ASI-DVB video signals up to 3Gbit/s. Each channel has automatic input clock rate and signal presence detection with selectable signal reclocking. This module is ideally suited for demanding digital multi-format broadcast and professional applications.

The module provides 4 SDI optical outputs and 2 SDI electrical outputs which can be mapped using the integrated 4x6 signal router. In non-reclocked mode the module will transparently pass any data between 15Mbit/s and 3Gbit/s. Support for ASI/DVB and SMPTE 310 signals is also provided.

Select from 18 wavelengths for CWDM applications, or select all 1310nm wavelengths for non CWDM applications. Up to 10 modules, (or 40 fiber TX channels) can be supported in a standard LYNX 2RU rack frame. The Fiber SFP sub-modules are secured on the backplane allowing for module removal and hot swapping without removing any modules rear I/O fiber connections.

Full remote control, status monitoring and error reporting is possible when using the LYNX control system.

Features

- 4 independent optical TX channels and 2 x electrical outputs
- Supports SDI/ASI/DVB and SMPTE 310 up to 3Gbit/s
- Selection of 18 wavelengths available for CWDM applications
- Reclocking or non-reclocking mode for each channel
- Auto-detects input clock rate
- Transparently pass data between 15Mbit/s and 3Gbit/s in non-reclocked mode.
- Input presence detection with LED indication for each channel
- Internal 4x6 signal router for flexible I/O mapping (remote only)
- LC fiber optic connections, single mode or multimode fiber
- Fiber SFP modules secured in backplane. Module can be freely removed or replaced without disconnection of fiber cables
- Remote control, status monitoring and error reporting when used with LYNX control system
- SNMP error reporting when used with master controller option
- Hot Swappable

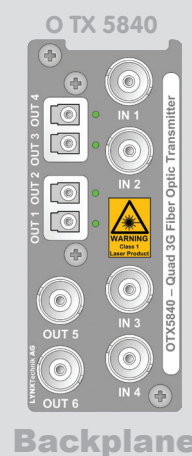
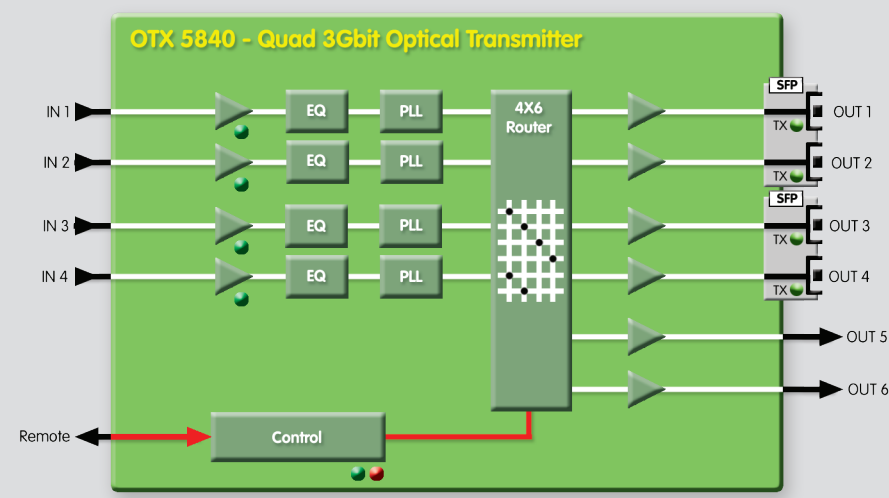
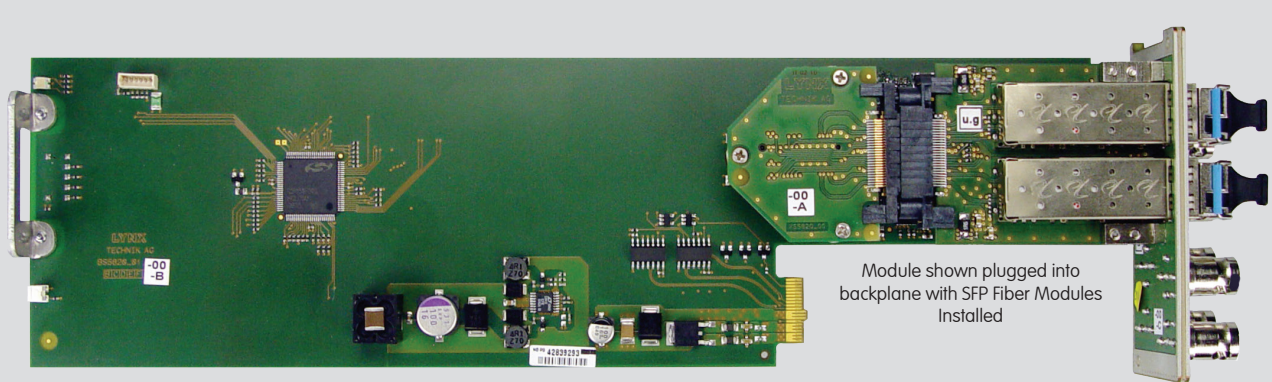

3Gbit Quad SDI Fiber Optic Transmitter

Specifications

SDI Inputs	
Signal type	Serial Digital Video SMPTE 259M, 292M, 424M DVB-ASI and SMPTE 310
Input level	0.8 v peak to peak
No. of Inputs	4
Input Impedance	75 Ohms
Connector	BNC
Return Loss	> 15dB (1.485Gbit) > 10dB (2.97Gbit)

Optical Outputs	
Signal type	SMPTE 297M - 2006
Connector	LC / PC Single Mode or Multimode*
No. Of inputs	4 (on 2 dual channel SFP fiber sub modules)
Wavelength	Wavelengths selected from option table.
Power	Refer to wavelength option selections
CWDM	Select wavelengths and dual channel SFP modules from the table provided.
Non CWDM	Use OH-TT-1 Option for dual 1310nm non CWDM transmitters

SDI Video Outputs	
Signal Type	Serial Digital Video SMPTE 259M, 292M, 424M DVB-ASI and SMPTE 310
Video standard	Follows input
Output level	0.8 v peak to peak
Output impedance	75 Ohm
No. Of Outputs	2
Connector	BNC
Return loss	> 15dB (1.485Gbit) > 10dB (2.97Gbit)
Jitter	< 0.20 UI (270 MHz) < 1.0 UI - Timing Jitter - (1.485Gbit - 2.97Gbit) < 0.20 UI - Alignment Jitter - (1.485Gbit - 2.97Gbit)

Performance	
Cable equalization	Up to 250M using Belden 8281 (270Mbit) Up to 140m using Belden 1694A (1.485Gbit) Up to 80m using Belden 1694A (2.97Gbit)
Control	Remote control possible when used with LYNX controller
Status monitoring (LED)	Signal presence (each input channel) plus general alarm

Operation modes	
4 channel Transmitter	in basic mode with no remote control inputs are mapped to outputs 1 to 1
Input / output mapping	A 4x6 Internal router can be used to freely assign I/O mapping when using the LYNX control system.
Re-clocking	Clocked or non-reclocked operation (selectable for each channel)

Electrical Specifications	
Operating Voltage	12 VDC
Power Consumption	< 7W
Safety	IEC 60950/ EN 60950/ VDE 0805

Mechanical	
Size	283mm x 78mm
Weight	CardModule 120g, connector plate 120g

Ambient	
Temperature	5°C to 40°C Maintaining specifications
Humidity	90% Max non condensing

Specifications subject to change

Settings and Control

Local Settings	
Re-clocking	clocked / non re-clocked for each input channel

Settings Available from Control System	
4 x 6 Router Control	

On Board Indicators / LEDs	
Input 1 Present / No Input	
Input 2 Present / No Input	
Input 3 Present / No Input	
Input 4 Present / No Input	
General Alarm Indicator – 3 Color	
TX fiber activity (on rear connection panel)	

*Note

We recommend the use of Single Mode fiber cable with these modules. Multimode operation is possible, but performance (distance) is heavily influenced by the type of Multimode cable. Single Mode cable **MUST** be used for any CWDM application.

CWDM Wavelength Selection

NOTE: Basic Module price **DOES NOT** include any SFP fiber transmitter modules. The required CWDM fiber optic transmitter wavelengths are selected from the table below. Each SFP sub module supports two wavelengths Please specify one option if only using two channels, and two options if using all four channels. For non CWDM applications please specify one (or two) **OH-TT-1** options, these options have dual 1310nm non CWDM transmitters.

Specifications	
Connector	Dual LC / PC
Power	-1 dBm typ. (CWDM modules) -5dBm typ. for OH-TT-1 option (non CWDM)
Max Distance	40km (nominal) for all CWDM options 10Km (nominal) for OH-TT-1 option (non CWDM)
Supported Cable	Single Mode
Wavelengths	Select from table below

SFP Module Selections	
Model Number	Wavelengths (dual channel)
OH-TT-1	1310nm, 1310nm (non CWDM)
OH-TT-4-1270-1290	1270nm, 1290nm (CWDM)
OH-TT-4-1310-1330	1310nm, 1330nm (CWDM)
OH-TT-4-1350-1370	1350nm, 1370nm (CWDM)
OH-TT-4-1390-1410	1390nm, 1410nm (CWDM)
OH-TT-4-1430-1450	1430nm, 1450nm (CWDM)
OH-TT-4-1470-1490	1470nm, 1490nm (CWDM)
OH-TT-4-1510-1530	1510nm, 1530nm (CWDM)
OH-TT-4-1550-1570	1550nm, 1570nm (CWDM)
OH-TT-4-1590-1610	1590nm, 1610nm (CWDM)

Ordering Information

Model #	Description	Includes
O TX 5840	3Gbit Quad Fiber Optic Transmitter	CardModule, Rear termination Panel + Mounting Screws, and Reference Manual (on CD)
Option: OH-TT-X-XXXX-XXXX	Transmitter SFP Sub Module	Select from table above, 2 max. Includes SFP module pre-installed in module backplane.