

AES Audio Embedder / De-embedder (balanced AES)

- Simultaneous embedding and de-embedding
- 3G SDI Level A and Level B support
- SDI video formats up to 3Gbit (1080p60)
- 4 x AES inputs / outputs with selectable audio groups
- Optional Fiber I/O
- Integrated 1 kHz test tone generator
- Automatic PCM / encoded audio detection
- Auto black if no video present
- Selectable SDTV 24 bit mode
- Video and Audio present LED indicators
- Internal full mono audio shuffling via yelloGUI

The PDM 1284 D is a versatile AES audio embedder and de-embedder designed for a wide range of SDI video formats up to 3Gbit. It supports balanced AES3 audio I/O using a 25 pin SubD connector.

Audio groups are selected using the rotary switches, and its possible to embed and de-embed additional audio groups by cascading modules together. Simultaneous embedding and de-embedding means the module will de-embed and output the audio from the selected audio group before overwriting with new audio (if required). The module automatically detects audio formats and will deactivate the sample rate converters to preserve encoded bit streams such as DolbyE.

The "auto black" mode uses a black video frame if no SDI input is present. This allows the module to embed audio even when no video source is available. This mode is useful if the module is being used in an "audio only" application. A 1 kHz test tone generator is included for audio testing purposes.



Shown with Fiber SFP Option Installed

The module is also compatible with the yelloGUI software package, which provides access to a host of additional internal settings which includes manual insertion of metadata (AFD,WSS,VI)

An SDI fiber input and output is also provided with a variety of plug in SFP options available.



Technical Specifications

SDI Input	1 x SDI video on 75 Ohm BNC connector SMPT E 424M, SMPT E 292M, SMPT E 259M 3G Level A & B-DL & B-DS according to SMPT E ST 425-1 with image formats 1280 x 720 and 1920 x 1080 Multi-standard operation from 270Mbit/s to 3Gbit/s SDTV (525/625) 720p and 1080p (23.98/24/25/29.97/30/50/59.94/60 Hz) 1080psf (23.98/24/25/29.97/30 Hz) 1080i (50/59.94/60 Hz) Return Loss: > 15dB to 1.5Gbit/s and > 10dB up to 3Gbit/s Automatic cable EQ (Belden 1694A cable) 250m @ 270Mbit/s, 140m @ 1.5Gbit/s, 80m @ 3Gbit/s
Fiber I/O	(optional) 1 x fiber optic input and output (see table) SMPT E 297M - 2006
SDI Output	1 x SDI video on 75 Ohm BNC connector SMPT E 424M, SMPT E 292M, SMPT E 259M 3G Level A & B-DL & B-DS according to SMPT E ST 425-1 with image formats 1280 x 720 and 1920 x 1080
AES Inputs	4 x AES3 balanced inputs on 25 pin SubD Connector (110 Ohm) AES group selection provided via rotary switch
AES Outputs	4 x AES3 balanced outputs on 25 pin SubD Connector (110 Ohm) AES group selection provided via rotary switch
Power	+12VDC @ 4.2W nominal - (supports 8 - 14VDC input range)
Physical	Size: 128mm x 90mm x 22mm (5.04" x 3.54" x 0.86") including connectors Weight: 200g (7.05oz)
Ambient	5 - 40°C (41 - 104°F) 90% Humidity (non condensing)
Model #	PDM 1284 D - (EAN# 4250479312852)
Includes	Module, AC power supply, SubD adapter PCB, transport case

Specifications subject to change

SDI Fiber Transmitter Options			
Model	Description	Power	
OH-TX-1-LC / ST / SC	SFP Fiber TX - Singlemode - LC, ST or SC conn. - 10km	-5dBm (1310nm)	
OH-TX-0-850-MM	SFP Fiber TX- Multimode - LC conn. - 300m	-5dBm (850nm)	
SDI Fiber Receiver Options			
Model	Description	Sensitivity	
OH-RX-1-LC / ST / SC	SFP Fiber RX - Singlemode - LC, ST or SC connector	-16dBm	
OH-RX-0-MM	SFP Fiber RX- Multimode - LC connector	-15dBm	
SDI Fiber Transceiver Options			
Model	Description	Power	Sense
OH-TR-1	SFP Fiber RX/TX - Singlemode, LC Connector - 10km	-5dBm	-18dBm
OH-TR-0-850	SFP Fiber RX/TX - Multimode, LC Connector - 300m	-5dBm	-15dBm
SDI CWDM Fiber Transmitter Options			
Model	Description	Power	
OH-TX-4-XXXX	CWDM SFP Fiber TX - Singlemode LC Conn. - 40km XXXX=Wavelength. 18 according to ITU T G692.2 1270nm through 1610nm	-1dBm	
SDI CWDM Fiber Transceiver Options			
Model	Description	Power	Sense
OH-TR-4-XXXX	CWDM SFP Fiber RX/TX - Singlemode LC Conn. - 40km XXXX=Wavelength. 18 according to ITU T G692.2 1270nm through 1610nm	-1dBm	-20dBm

PDM 1284 D Application

The basic SDI embedding and de-embedding applications for the PDM 1284 D are somewhat obvious, but with the “auto-black” mode the modules can be used to transport audio signals only. This provides a very cost effective way to transport multichannel audio over fiber without the need for external optical multiplexing. The example below shows how two modules in each location can be used to transport 16 x digital audio signals between two locations over fiber.

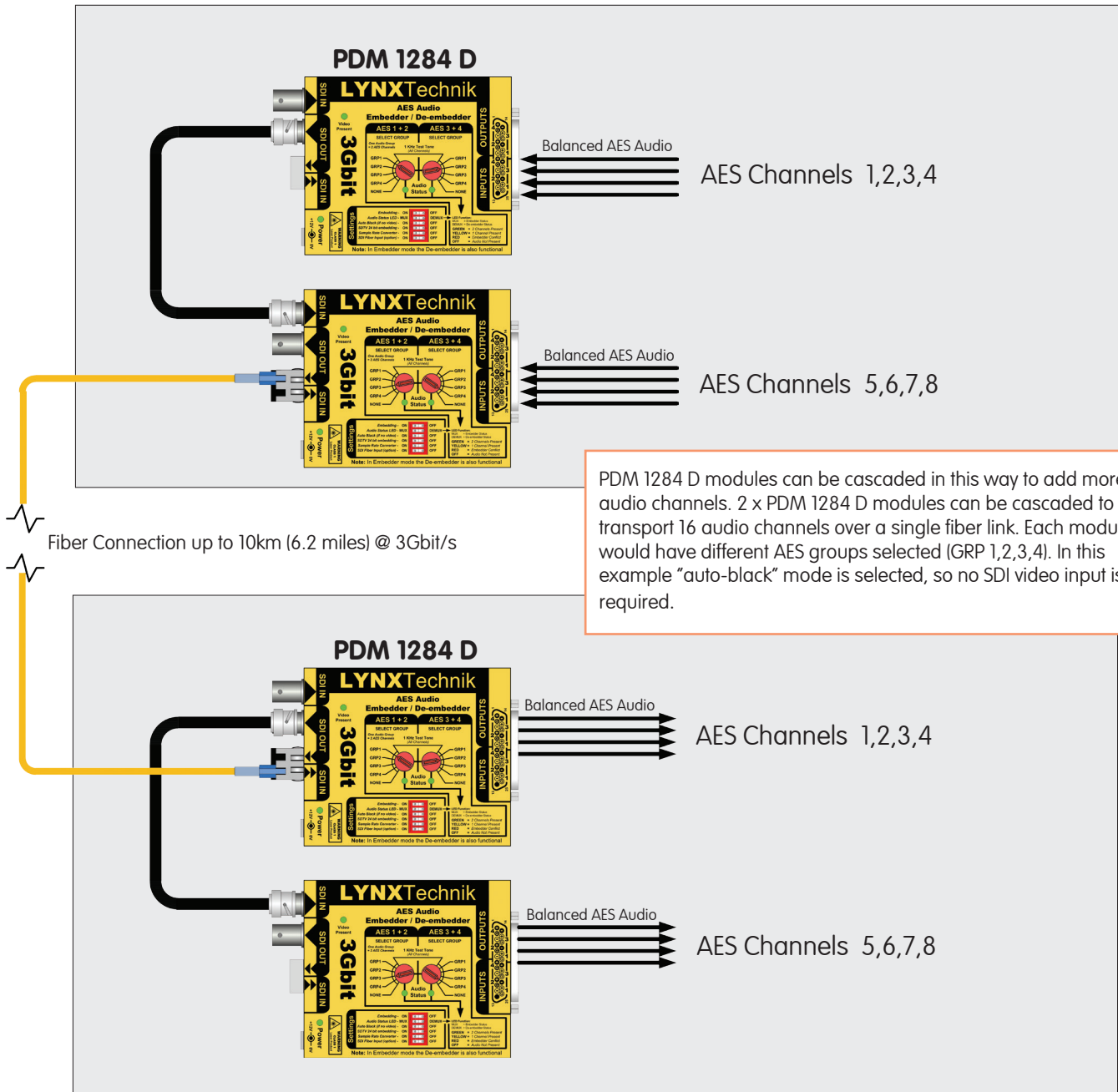

PDM 1284 D modules can be cascaded in this way to add more audio channels. 2 x PDM 1284 D modules can be cascaded to transport 16 audio channels over a single fiber link. Each module would have different AES groups selected (GRP 1,2,3,4). In this example “auto-black” mode is selected, so no SDI video input is required.